

Past, Present and Future of Virtual and Augmented Reality



Jacquelyn Ford Morie

The Distinguished Speakers Program
is made possible by



**Association for
Computing Machinery**

Advancing Computing as a Science & Profession

For additional information, please visit <http://dsp.acm.org/>

ABOUT ACM



ACM, the Association for Computing Machinery is the world's largest educational and scientific computing society, uniting educators, researchers and professionals to inspire dialogue, share resources and address the field's challenges.

ACM strengthens the computing profession's collective voice through strong leadership, promotion of the highest standards, and recognition of technical excellence.

ACM supports the professional growth of its members by providing opportunities for life-long learning, career development, and professional networking.

With over 100,000 members from over 100 countries, ACM works to advance computing as a science and a profession. www.acm.org

Outline

- VR – some history
 - My involvement
 - A few notable VR experiences
 - The doldrum years
 - Current state and applications
- AR – some history
 - Notable AR apps
 - My involvement
 - Current State
- The future of AR/VR



Virtual Reality

- In the 1960s DoD developed it for training
 - Wright-Paterson AFB -> Super Cockpit with Tom Furness
 - Ivan Sutherland
- Reached the public mid-late 1980s
 - NASA pioneering use of VR for telerobotic operations & training
 - VPL and rise of early VR industry
 - From Matsushita to VR Navigator
- Hope and hype and ultimate fall from favor
 - Media showed a dystopian future
 - Not enough access by the public
 - Used sophisticated equipment that was \$\$\$\$
 - Stand alone systems primarily, single purpose
 - Rise of the web and more accessible social networks



Creating Virtual Reality

- Precedents in Science Fiction, spectacle events and theme parks
- Military researchers and futurists imagined how new forms of digital technology could change the world

A display connected to a digital computer ... is a looking glass into a mathematical wonderland.

The ultimate display would, of course, be a room within which the computer can control the existence of matter. A chair displayed in such a room would be good enough to sit in. Handcuffs displayed in such a room would be confining, and a bullet displayed in such a room would be fatal.

– Ivan Sutherland

sensorama

3-D MOVIES

STEREO SOUND
VIBRATIONS
WINDMASS
WIND



Mort Heilig

Sensorama (1950s)



Mort Heilig HMD (1960)



Oct. 4, 1960

M. L. HEILIG

2,955,156

STEREOSCOPIC-TELEVISION APPARATUS FOR INDIVIDUAL USE

Filed May 24, 1957

3 Sheets-Sheet 1

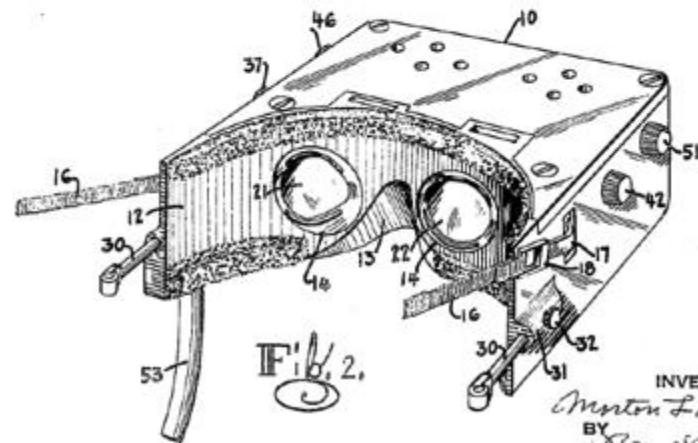
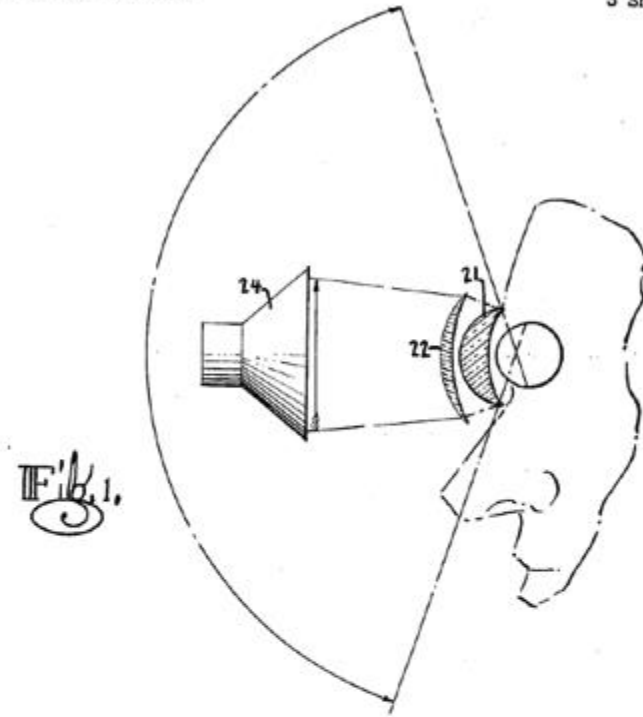

INVENTOR
Morton F. Heilig
BY *Broggsward*
his ATTORNEYS

Ivan Sutherland

HMD (1968)

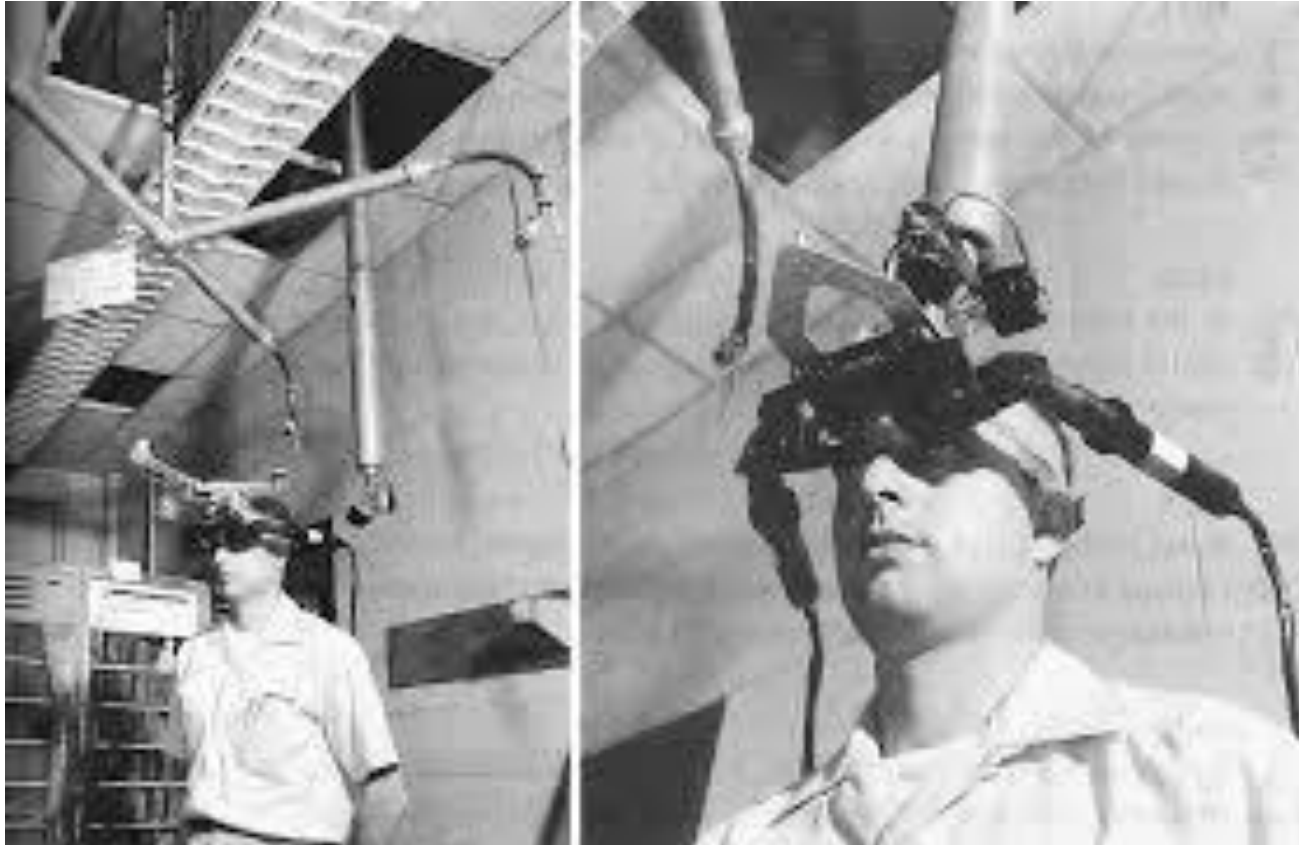

NASA's Role



NASA's Role

- NASA Ames HMD (1981-1984)
 - By McGreevy and Humphries, with Scott Fisher
 - Used LCD watchman displays
- Followed by NASA's VIEW system
 - Polhemus tracker
 - Leep optics-based HMD
 - 3D Audio with Crystal River's Convolvotron
 - Gesture tracking with VPL's Data Glove
 - Remote cameras for tele-robotics work



VPL's Role

- Jaron Lanier
- Founded first commercial company (1984)
 - Data Glove
 - Eye Phones
 - RB2 – networked VR
- Worked with NASA & Timothy Leary!
 - Bay area fans and psychedelic
 - Led to a Cyberpunk counterculture

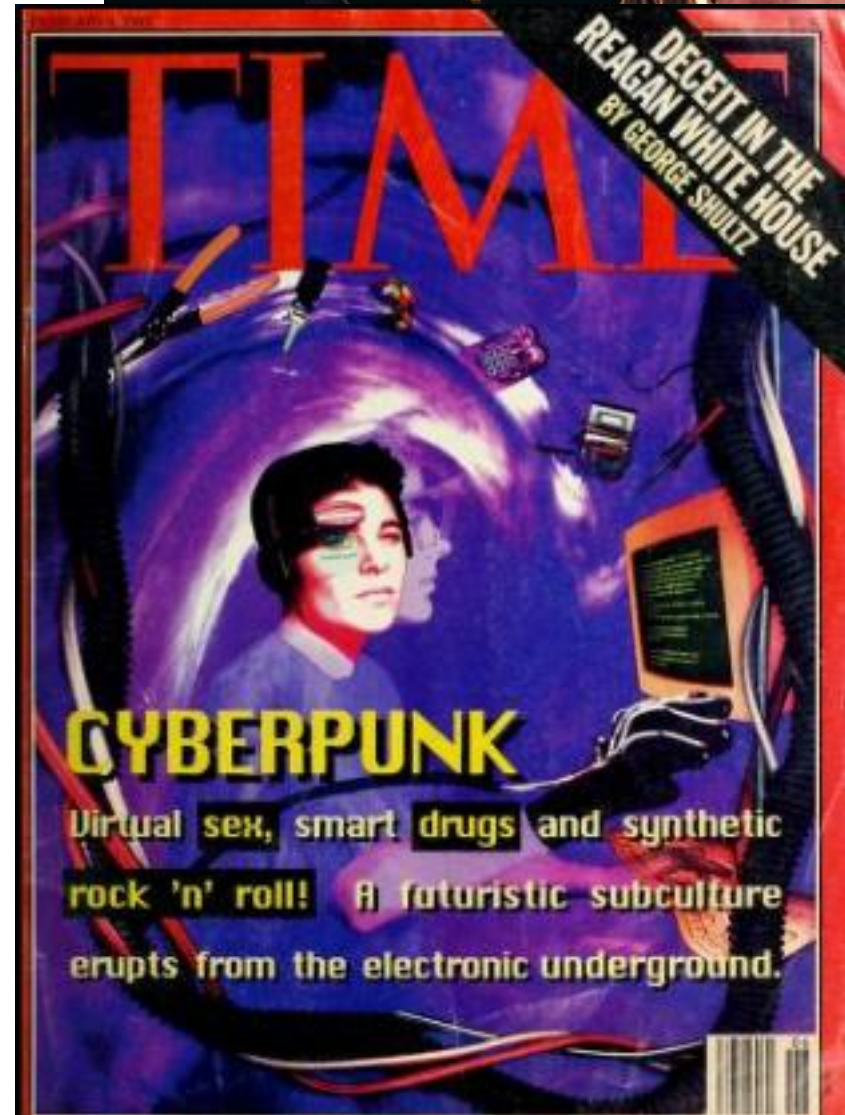

My first VR experience: 1989

Buzz words:

- Trippy
- Seductive
- Mind amplification
- A window to wonderland
- A microscope for the mind
- An alternate reality



VR could be all these things, but mostly it wasn't.
I was intrigued, but bored

Virtopia

Designed to evoke emotional responses

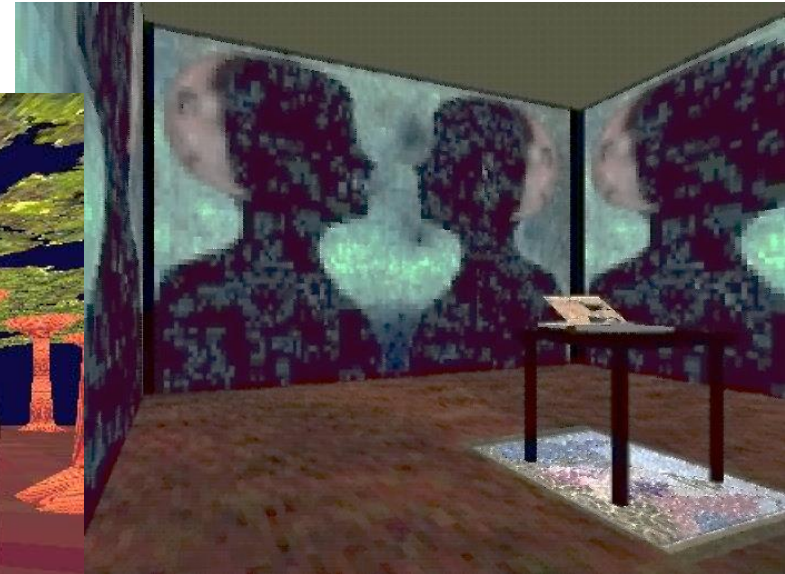
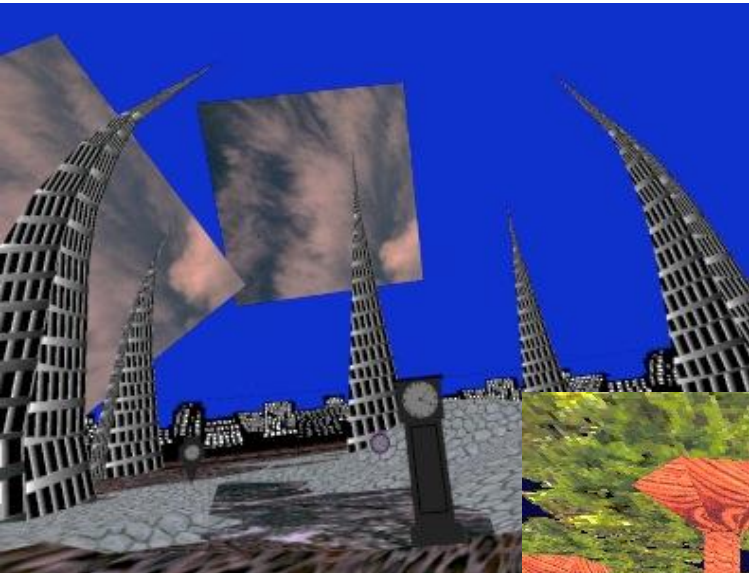

Virtopia

Designed to evoke emotional responses

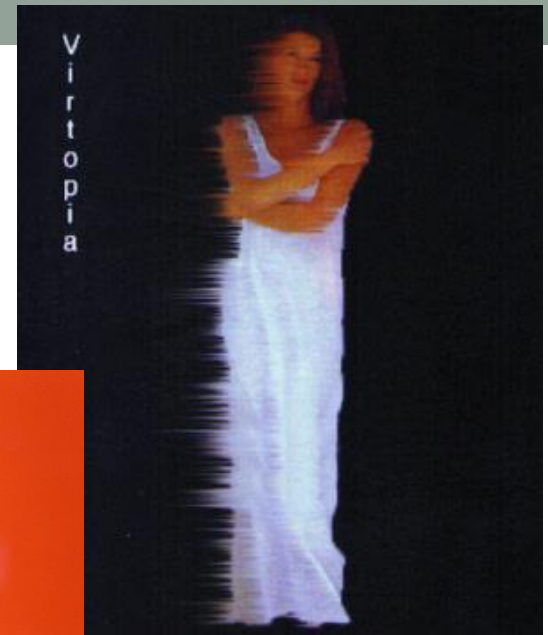

Polyshop

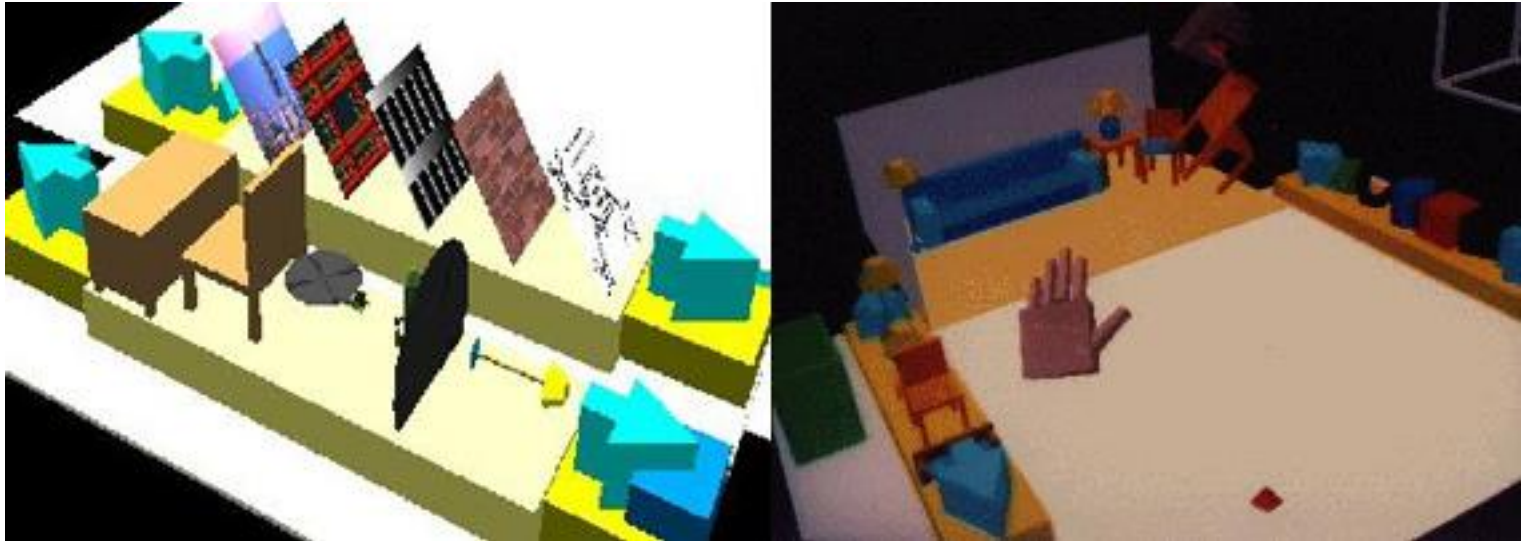

Polyshop (UCF's Realtime Simulation Group)

Practical applications – building CAD models together from within the virtual environment

The ToyScouts c. 1992



VR emerging as a unique art form & medium

- Banff Centre's Art and Virtual Environments Program
- Early 1990s
- 9 pieces realized during a 3 year period
- Some of the most advanced VR being done

Banff Centre for the Arts



Brenda Laurel & team
Placeholder 1992

Banff Centre for the Arts



Toni Dove & Michael Mackenzie
Archaeology of a Mother Tongue 1994

Maurice Benayoun

World Skin 1997



Char Davies

Osmose 1995 and *Ephémère* 1998

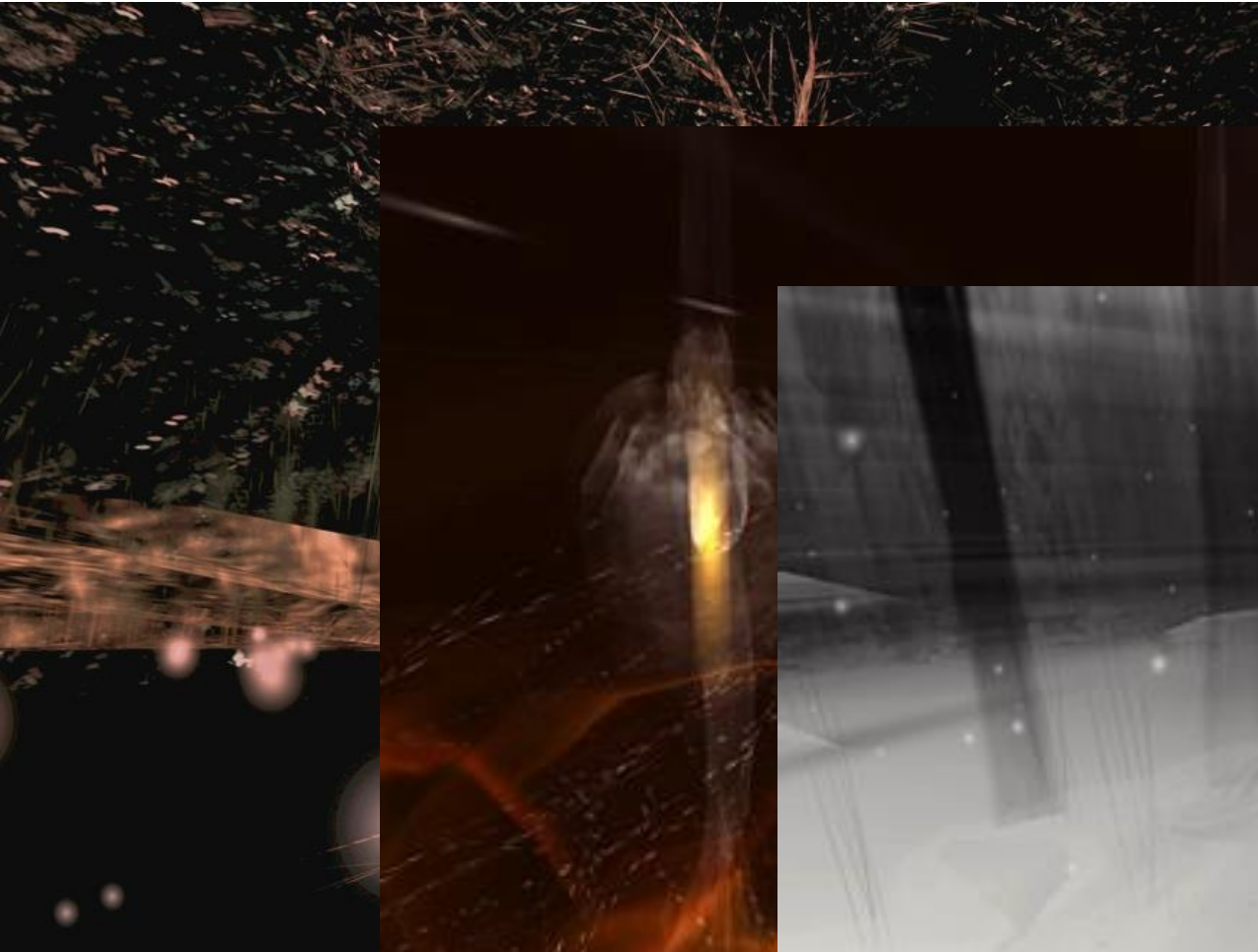

Char Davies

Osmose 1995 and *Ephémère* 1998

It takes a few minutes to adjust to the space, but then you are not in the museum. It's like dying and going to heaven.

Just to be there floating... It's all of a whole – the light, the transparency and the texture. And the way you move – it's stunning.

It's really hard to talk and put words together after that.

Tamiko Thiel & Zara Houshmand



Beyond Manzanar 2000

Morie & SEE team (USC ICT)

DarkCon 2001-2005

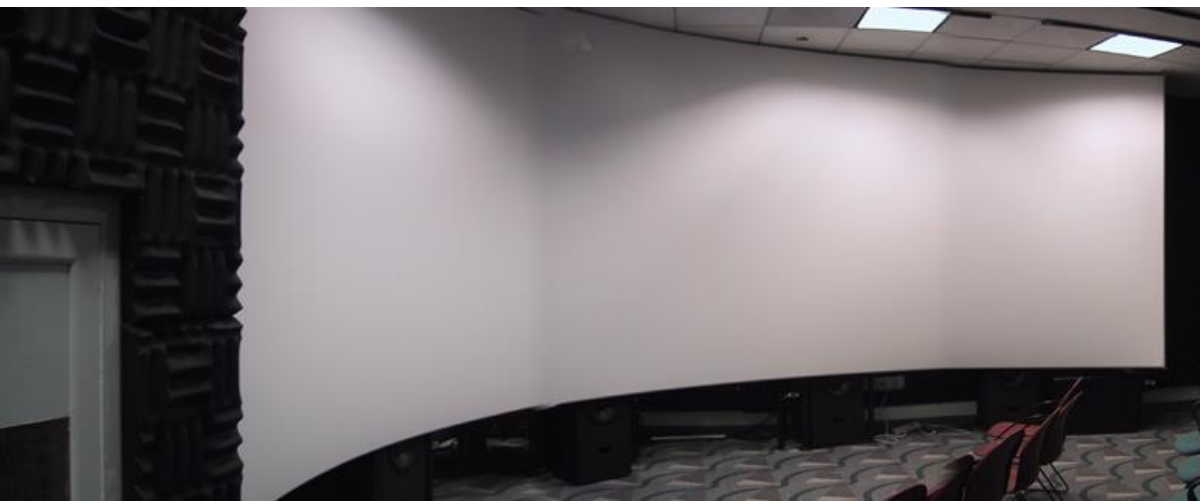
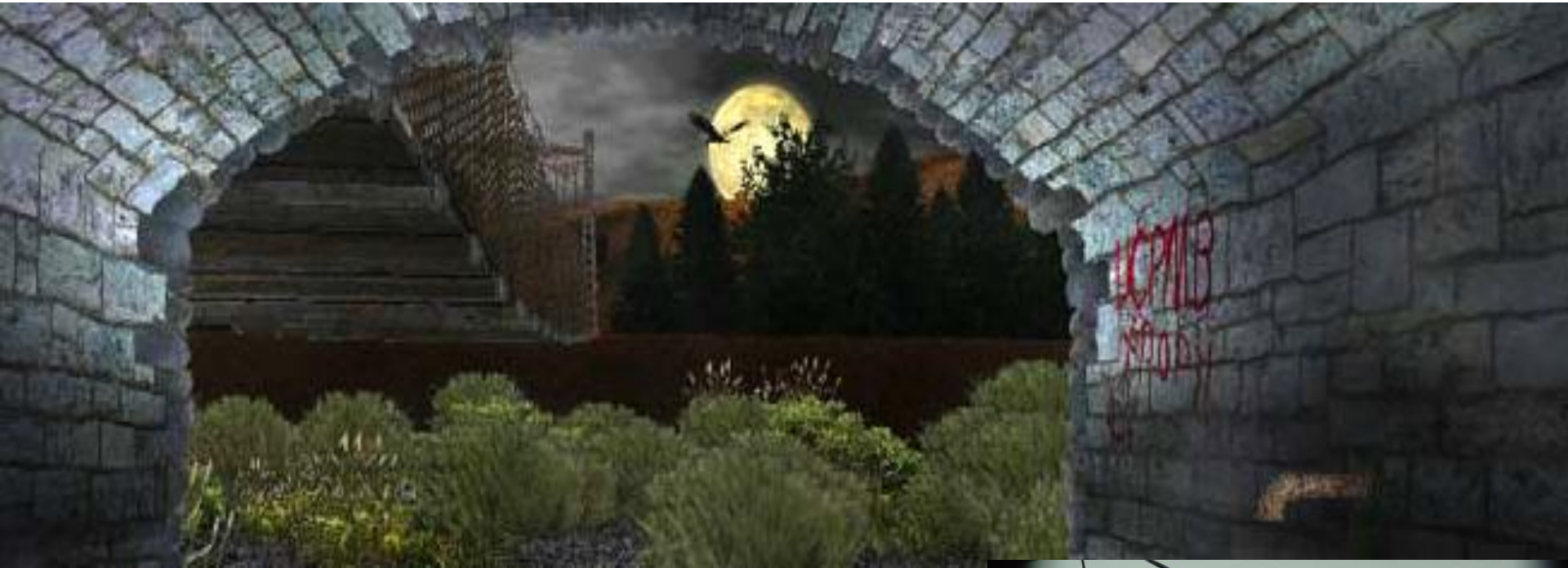

Patented scent collar

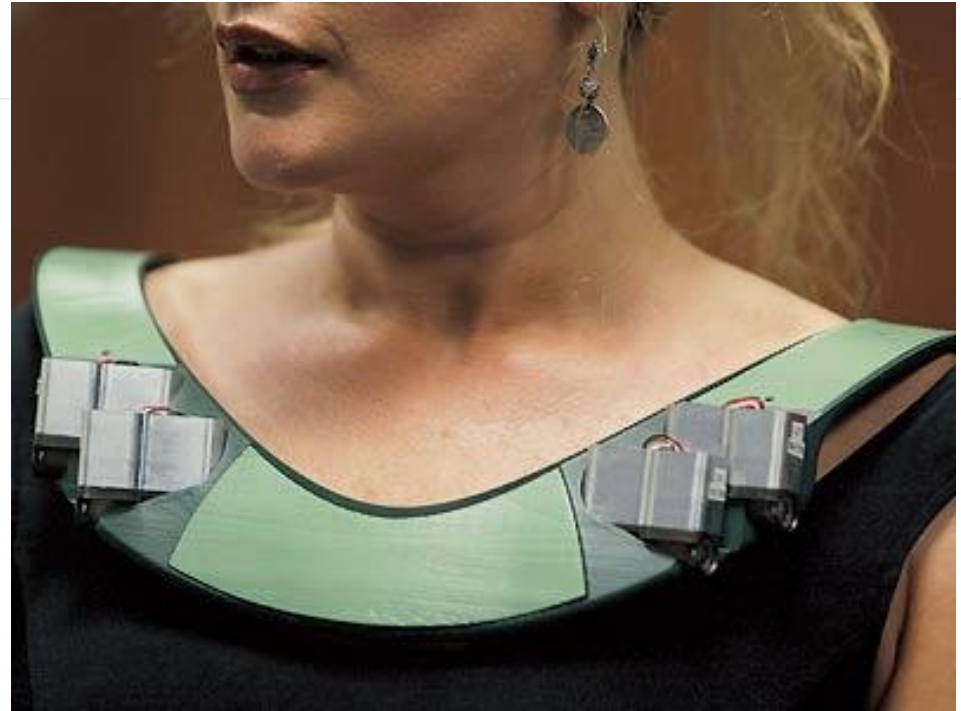

Scent delivery device and method of simulating scent in a virtual environment

US 7484716 B2

ABSTRACT

A cartridge for releasing scents through a digital trigger mechanism. Also disclosed is a portable, wearable, lightweight necklace or "collar," capable of holding 1 to 12 cartridges.

IMAGES (7)

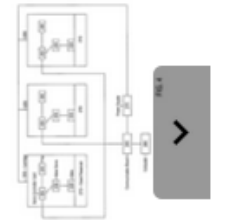
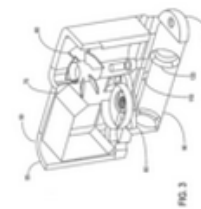
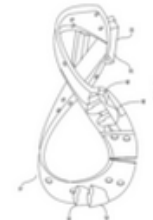
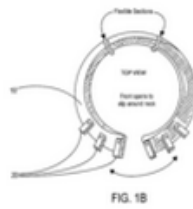
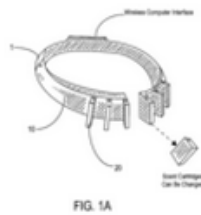
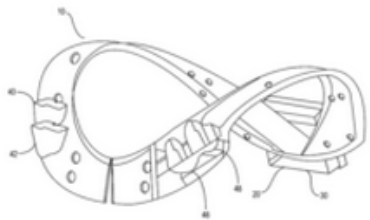

Memory Stairs

2005-2007



Meaning and Emplacement in Expressive Immersive Virtual Environments

2007 PhD at UEL

VR's doldrums

- Roughly the early 2000s
- Still much research going on
 - ISPR and the MIT Journal
 - Studies trying to tease out what makes VR so powerful
- Still expensive and less and less funding sources
- Research from Mel Slater, Jeremy Bailenson, Skip Rizzo and others providing key insights



Virtual Reality's new wave



Virtual Reality

- Virtual Reality (VR) then
 - Since late 1980s (starting in the 1960s)
 - Used sophisticated equipment that was \$\$\$\$
 - Stand alone systems primarily, single purpose
 - NASA pioneered use of VR for telerobotic operations & training + the DoD for training
- Virtual Reality (VR) now
 - Palmer Luckey's disruption – less \$\$\$
 - More generalized systems – easier to use
 - More hearts and minds on it!



Virtual Reality Applications Then

VR is malleable – beneficial in so many areas:

- Skills training (wayfinding to surgery)
- Health applications
- Behavioral therapy
- Entertainment arenas
 - (LBE, Art, Design, Industry)

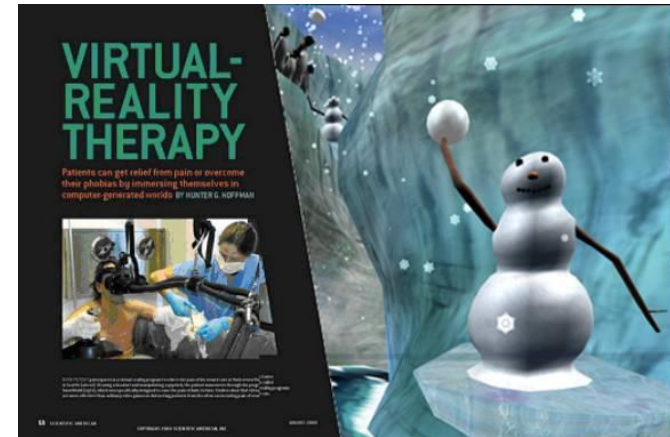

Virtual Reality Applications Now



Virtual Reality Flavors Today

- Live streamed events
- 360 Video aka Cinematic VR
- 360 Video plus photogrammetry
- VR news, storytelling, sports
- CGI based environments (game, animations & custom); varying degrees of other senses
 - Fully spatialized sound, haptics, scents
- Mobile VR (e.g) Google cardboard; new Viewmaster, Gear VR
- Full HMD delivered with robust tracking (tethered)



Virtual Reality Domains Today

- Concerts
- Sports
- Touring
- VR news
- VR Storytelling
- VR for sports
- VR for industry and business
- VR for Healthcare
- Artistic VR



VR for live events



VR for sports

- Fans
- Players
 - E.g Tampa Bay Rays using EON Sports VR for the batters to face the pitchers they will be playing against



VR for Real Estate & Hospitality services

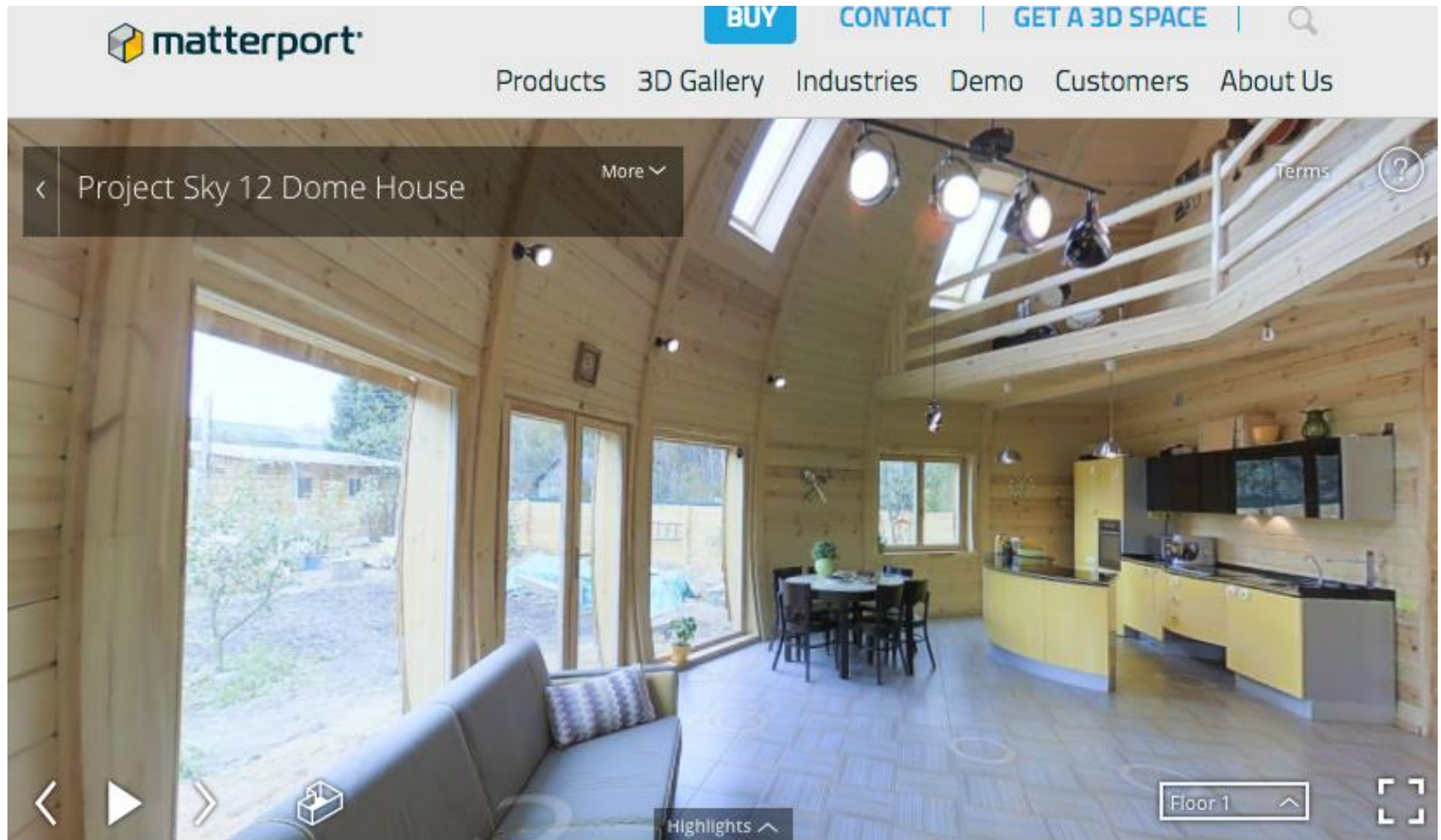

VR for education and history



VR for health

- Skip Rizzo's work with PTSD



VR for health

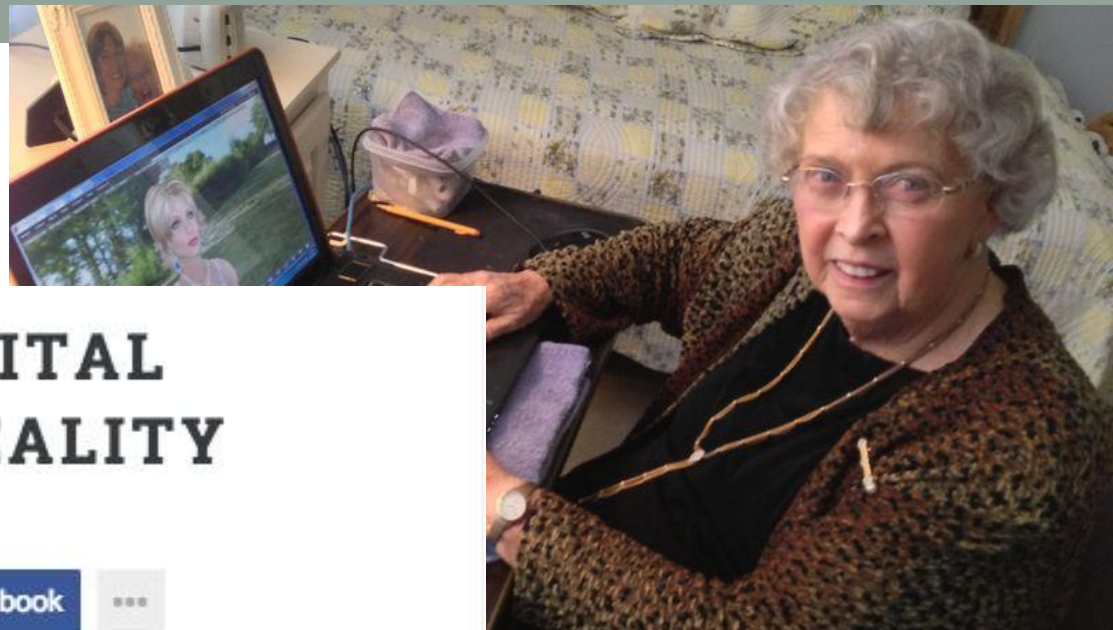

CEDARS-SINAI HOSPITAL ADOPTS VIRTUAL REALITY

24



Share on Twitter



Share on Facebook



SHARES



FEBRUARY 16, 2016



0



VR for health

Virtual Reality Therapy Could Be Used To Treat Depression

The new therapy could one day help improve symptoms by teaching self-compassion.

🕒 02/17/2016 06:05 pm ET



Carolyn Gregoire

Senior Health & Science Writer, The Huffington Post



FOL



Hu

VR Applications

And beyond ... “Inside NASA’s Version of the HOLODECK”

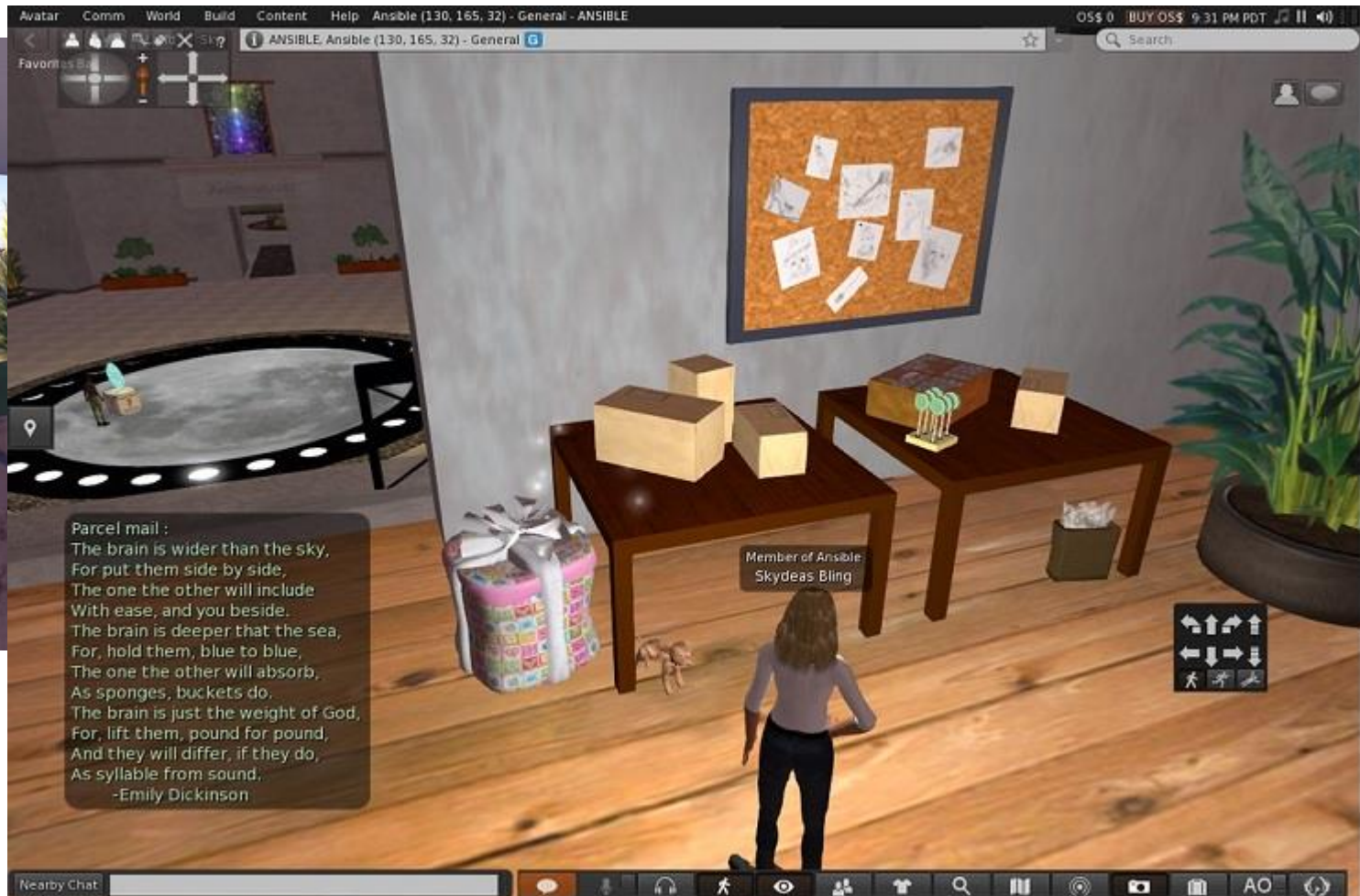

VR \$\$\$

REAL MONEY

Goldman Sachs projects that revenue in the global VR market will grow to \$80 billion by 2025. Of that, \$35 billion will be linked to software, with video games leading the way.

SOFTWARE SEGMENT	2025 REVENUE (BILLIONS \$)	ESTIMATED USERS (MILLIONS)
Video games	\$11.6	216
Health care	\$5.1	3.4
Engineering	\$4.7	3.2
Live event ticket sales	\$4.1	95
Video entertainment	\$3.2	79
Real estate	\$2.6	0.3
Retail	\$1.6	32
Military	\$1.4	0.7
Education	\$0.7	15

Source: Goldman Sachs

What are we creating, & Why?

- What's the press sees vs. what's really out there
- Meaningful applications



Nonny de la Peña

Immersive Journalism (2009-present)

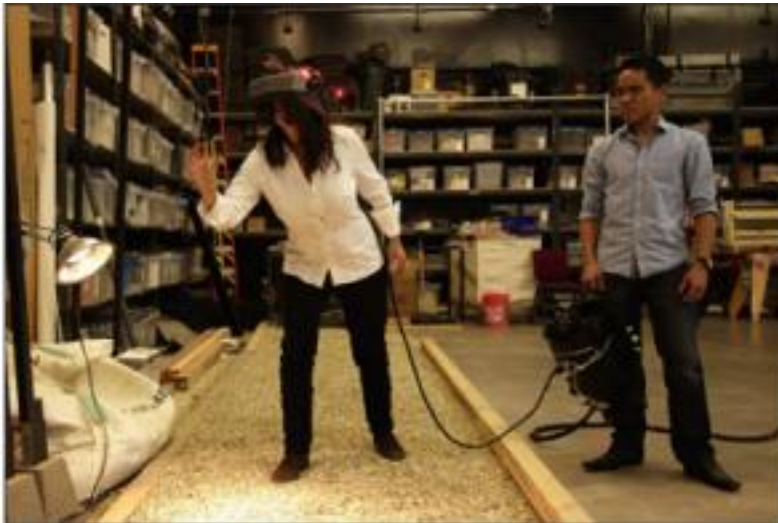

Hunger 2014

What will be Virtual Reality's future?



Tech devs that will impact VR/AR

Nvidia unveils the GTX 1060: Faster than a GTX 980 for \$250

Hot on the heels of AMD's mainstream RX 480, you can buy the GTX 1060 on July 19.

by Mark Walton (UK) - Jul 7, 2016 6:10am PDT

[f Share](#) [Tweet](#) [Email](#) 215



Tech devs that will impact VR/AR

- The world's leading proponents of 5G, the next-generation mobile communications technology, say it will deliver wireless transmission speeds 100 times faster than what current 4G networks provide by 2020
- Mobile advancements
- But issues too

Issues that may impact VR

- https://www.researchgate.net/publication/301891235_What_Is_Virtual_Reality

What Is Virtual Reality?



Working Paper · May 2016

DOI: 10.13140/RG.2.1.4415.0643

05/2016, Affiliation: Neogaian Interactive, Version: 1, State: In Progress, DOI: 10.13140/RG.2.1.4415.0643



1st [Brenda Laurel](#)

· 10.6 · NEOGAIAN Interactive

Description

Before we spread the term "VR" so thinly that it no longer means much (as we did in the 1990s), let's have a look at some of the formal and structural characteristic of what was and is Virtual Reality and have a look at what some of the designers of first-wave VR learned by designing and building it.

Mainstream VR?

- Google cardboard give away

GOOGLE CARDBOARD'S NEW YORK TIMES EXPERIMENT JUST HOOKED A GENERATION ON VR

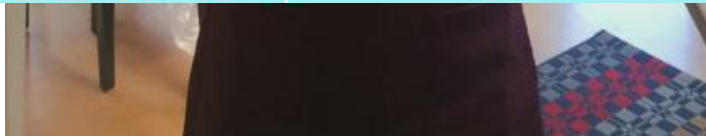

Issues that may impact VR

- The power of VR
- Being called an empathy machine
- There is already sexual harassment in social VR worlds
- Will it affect our eye sight and other physiological aspects?
- Will it be addictive?
- Will it be used to manipulate people? Behavior modification (without permission)
- False memories?



Augmented Reality (AR)



Includes the physical world – a.k.a. Mixed Reality

Augmented Reality (AR)

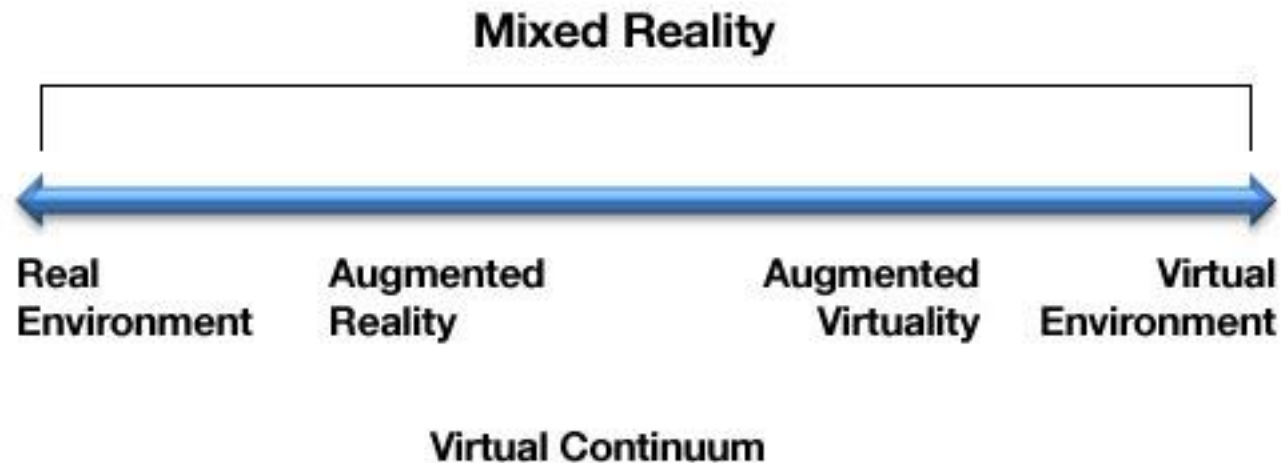

Actually a continuum from VR \leftarrow \rightarrow AR

Milgram, Paul; H. Takemura; A. Utsumi; F. Kishino (1994). "Augmented Reality: A class of displays on the reality-virtuality continuum" (pdf). Proceedings of Telematcher and Telepresence Technologies. pp. 2351–34. Retrieved 2007-03-15.

AR History

- Off shoot of early VR technology
- Term coined by Prof Tom Caudell for his work at Boeing for aircraft technicians
- Mark Billinghurst, under Tom Furness at the HIT Lab (UW) invented the AR “Magic Book” as part of his EE PhD thesis “Shared Space: Exploration in Collaborative Augmented Reality” (2002)



AR History

- Early AR required markers or fiduciarities of some sort to position the digital overlays
- AR also uses wearables, like Steve Mann's (MIT) pioneering work, which overlaid information onto the video scene captured via a camera
- Predecessor of Private Eye and Google glass

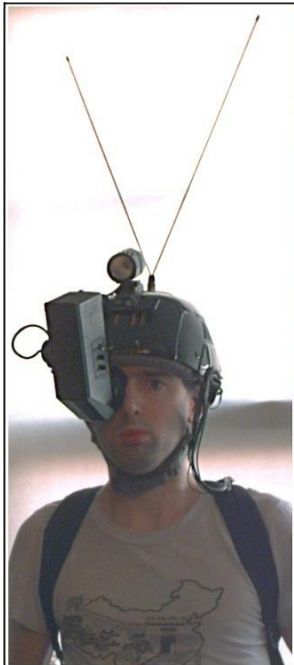

(a)
1980



(b)
Mid 1980s



(c)
Early 1990s



(d)
Mid 1990s



(e)
Late 1990s

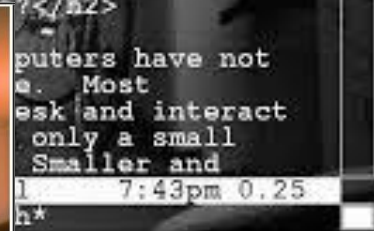

AR today

- Most apps currently use Smart Phones, and hand held devices (large installed user base)
- Can use markers or GPS along with computer vision and photogrammetry, SLAM depth cameras and more



AR for Engineering & Construction

- Smart field of views for planning and remodeling

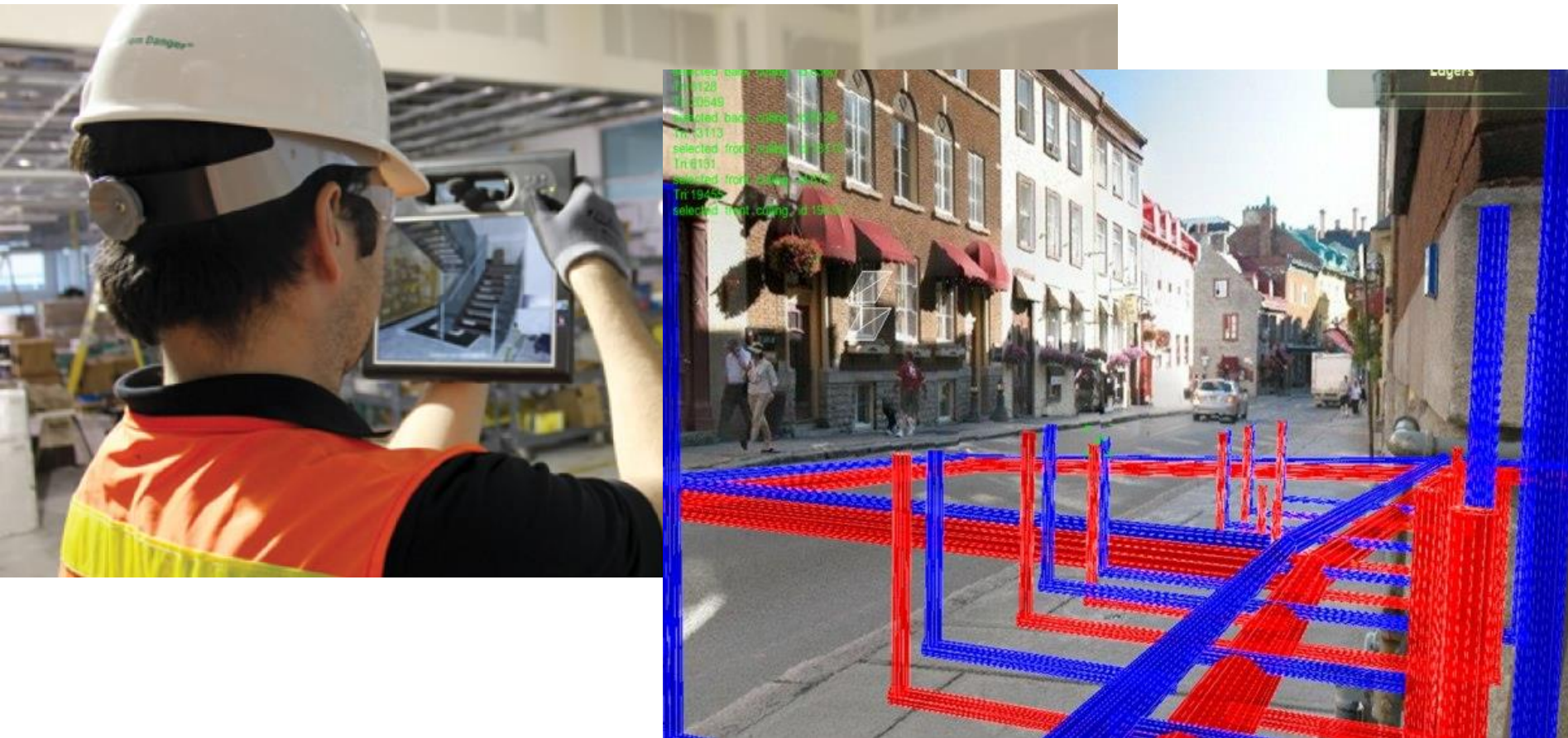

AR for Industry

- Training and real time augmented maintenance manuals



AR for sports

- Fans
- Players

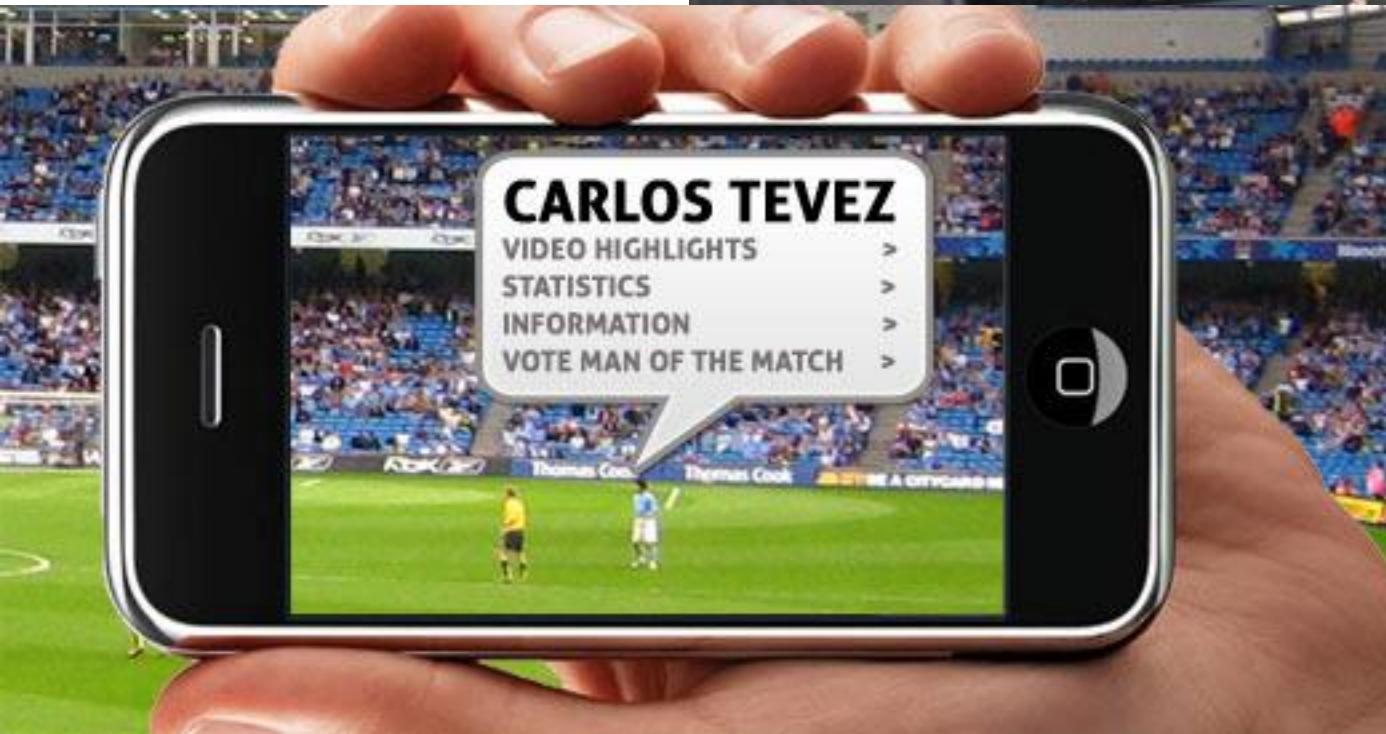

AR for marketing & sales

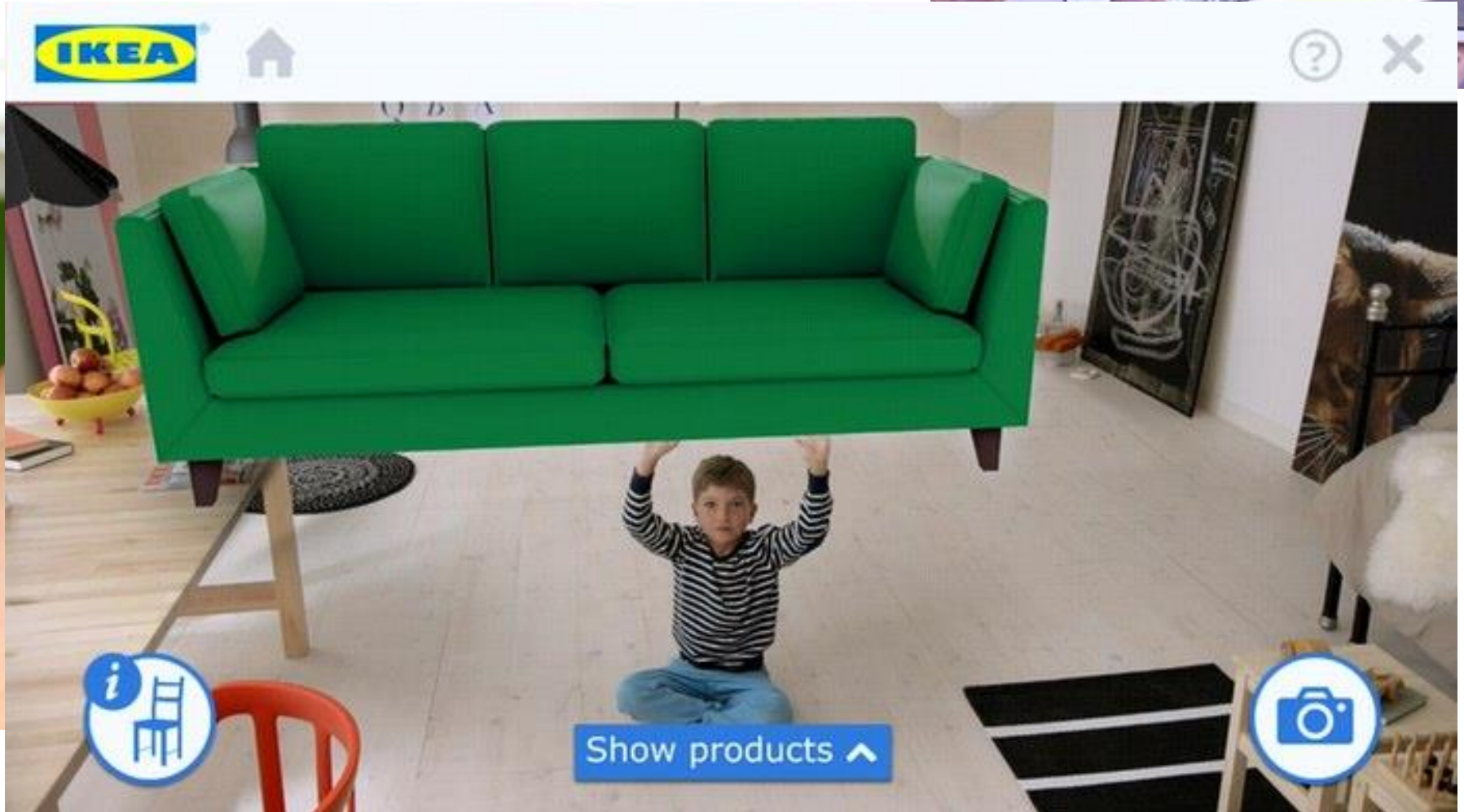
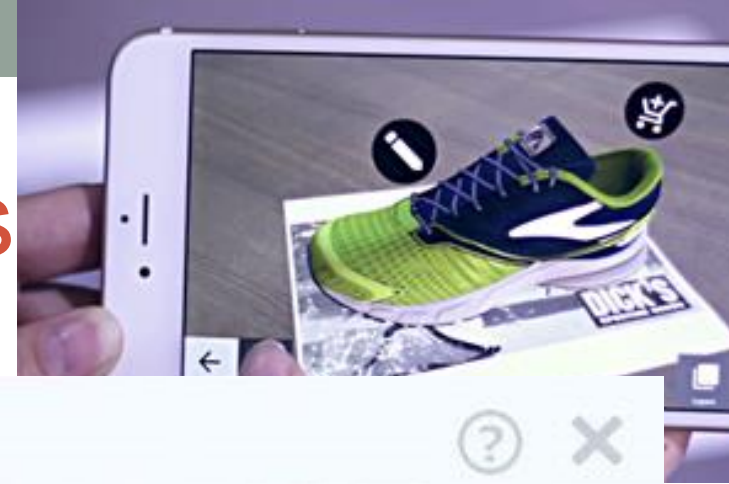

AR for travel & storytelling



Augmented Reality mass adoption?

- Cover of New Yorker

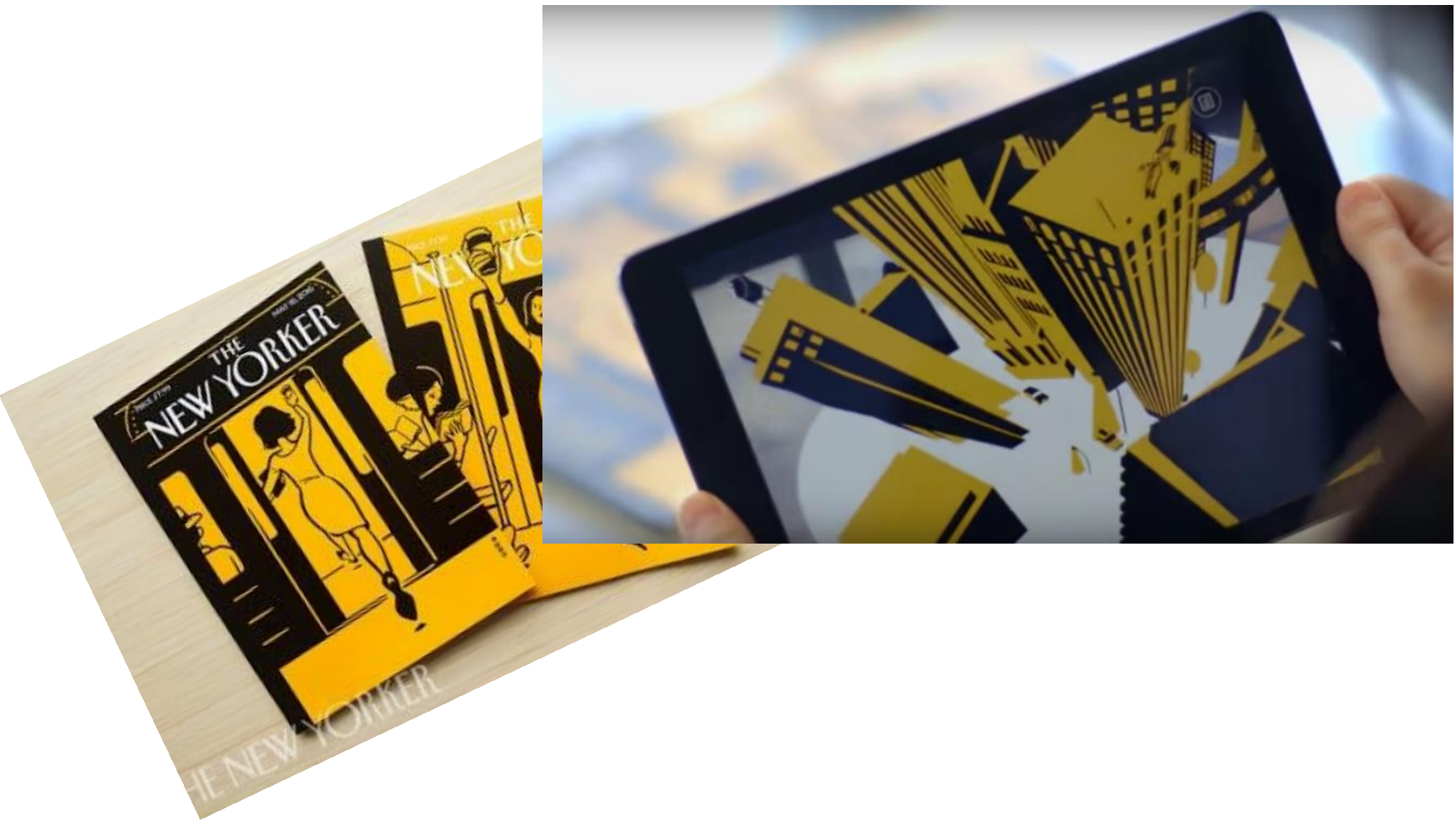

AR for Games

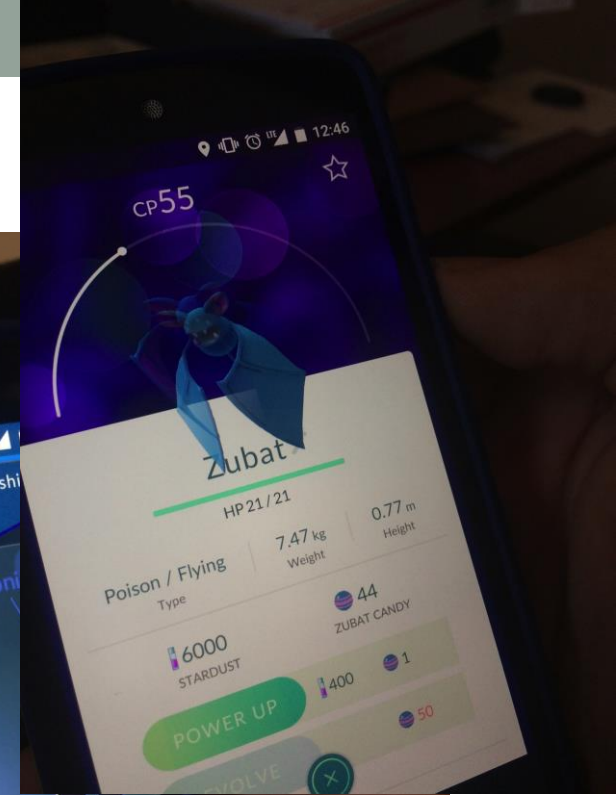
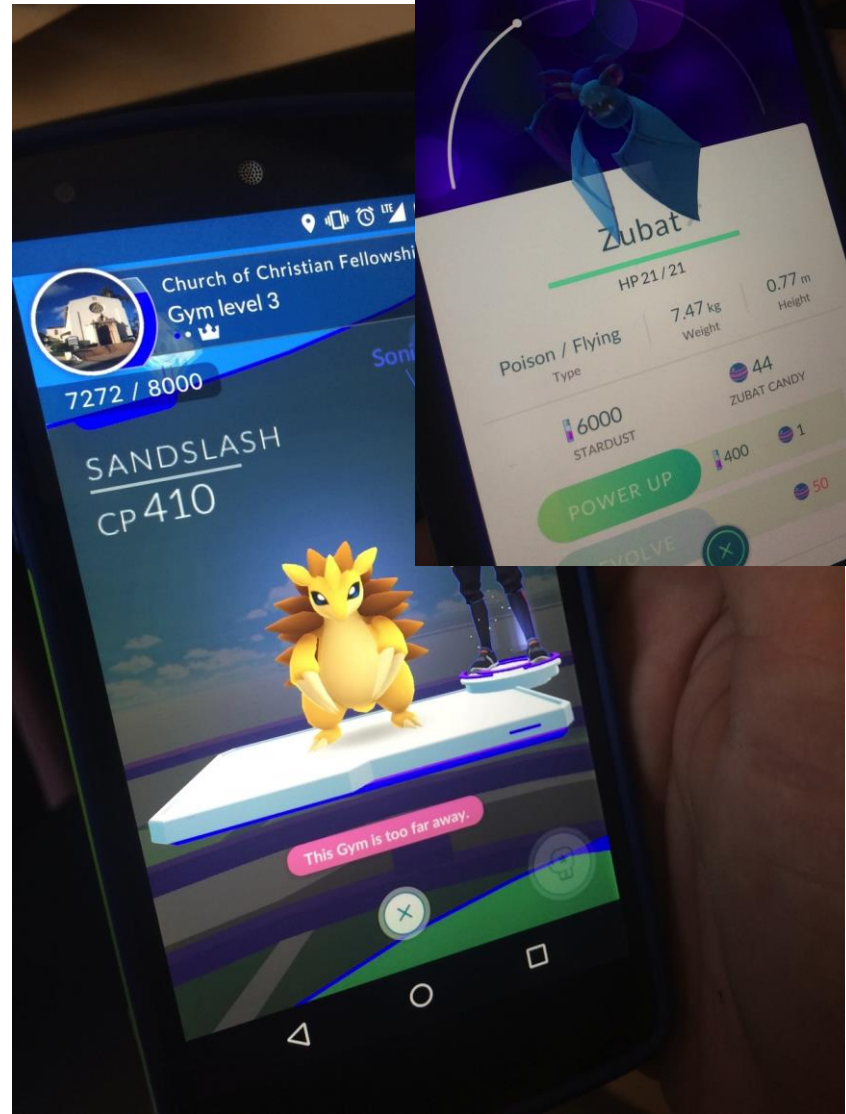

AR for Games

Nintendo's worldwide video game software sales (in million units)

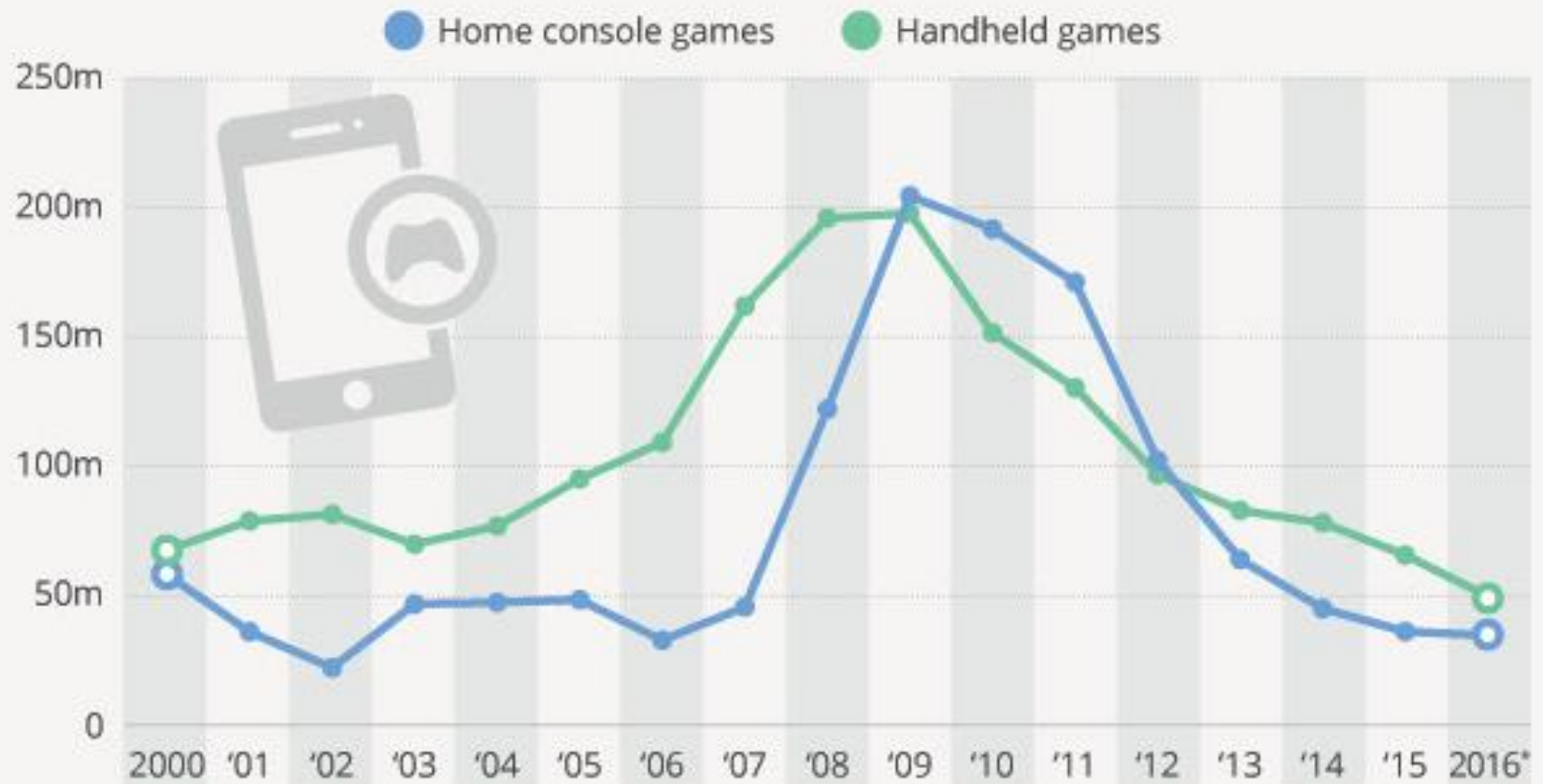

What's next for AR?

- From hand-held devices to wearable displays

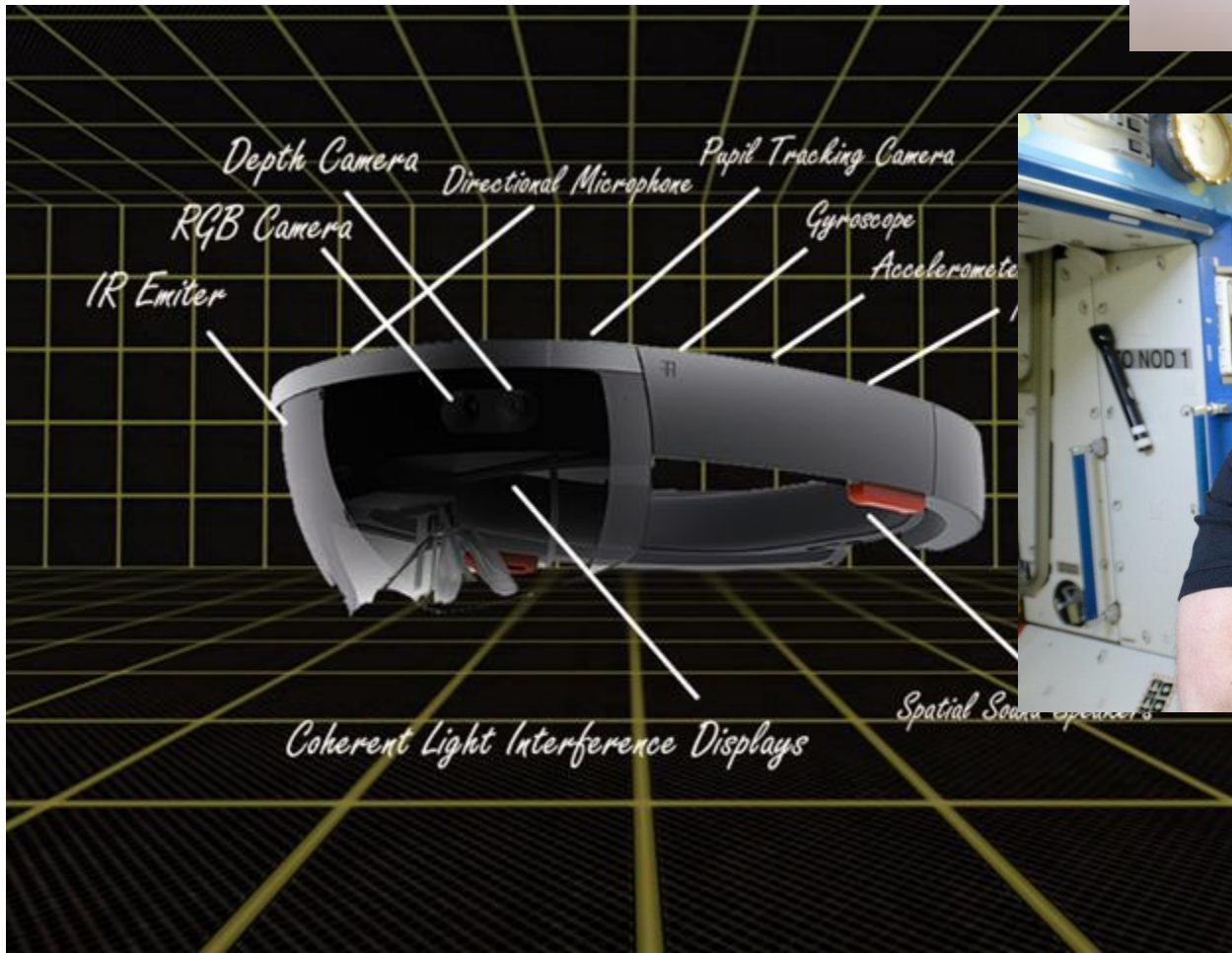

AR's new hype cycle?

- Magic Leap's story

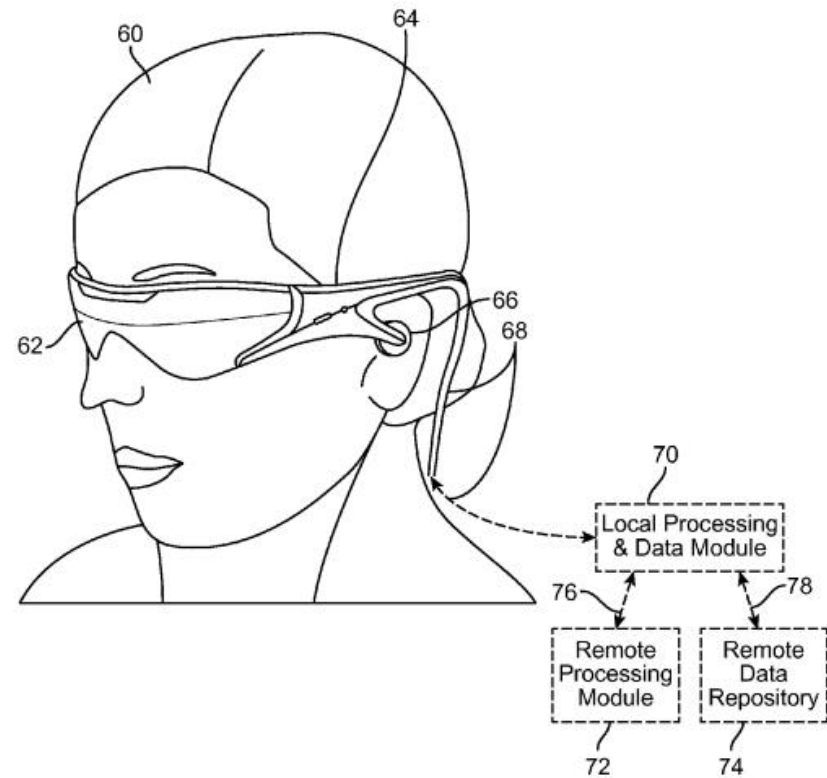

What will be Reality's next wave?



Future displays

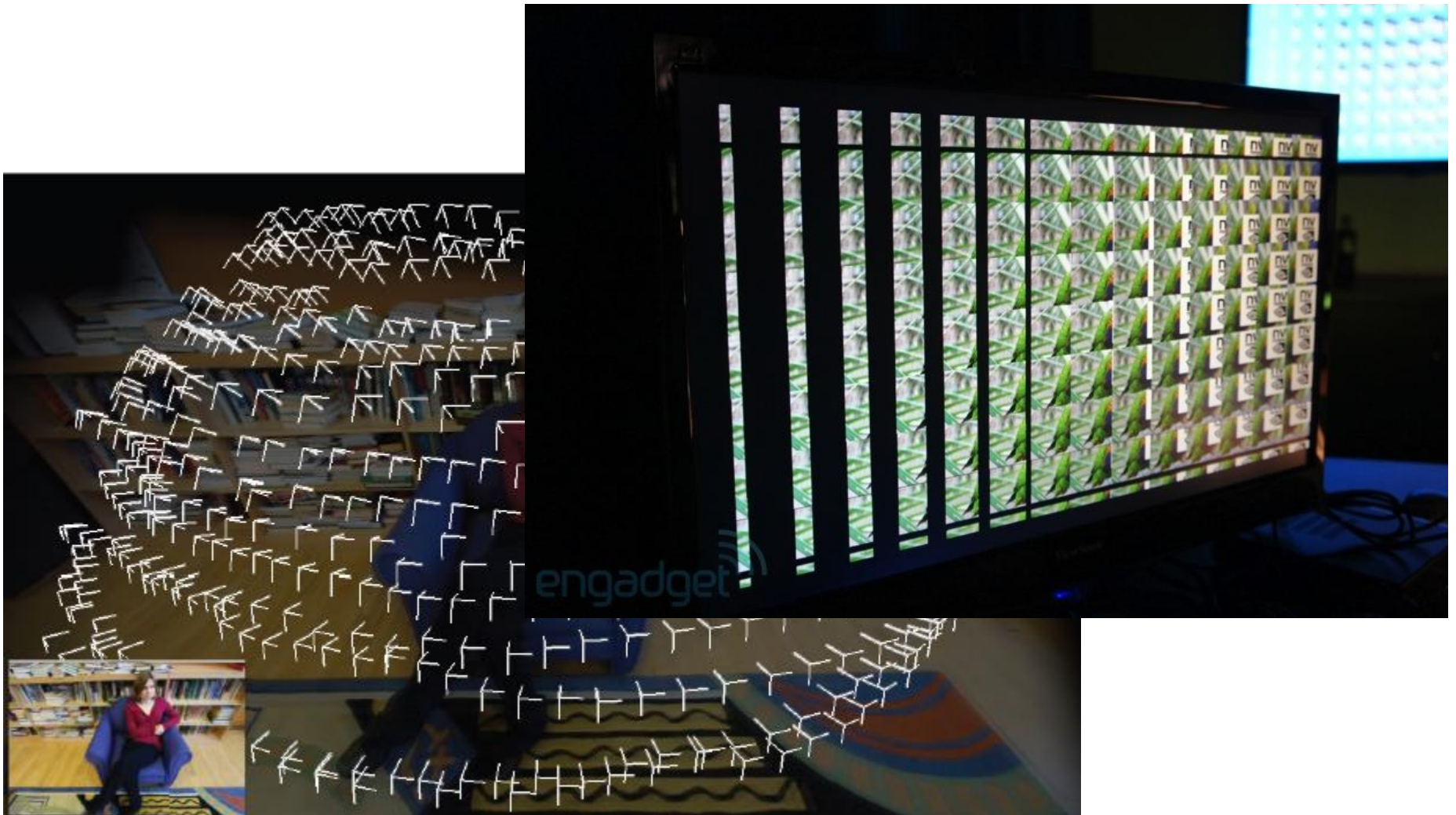

Future displays

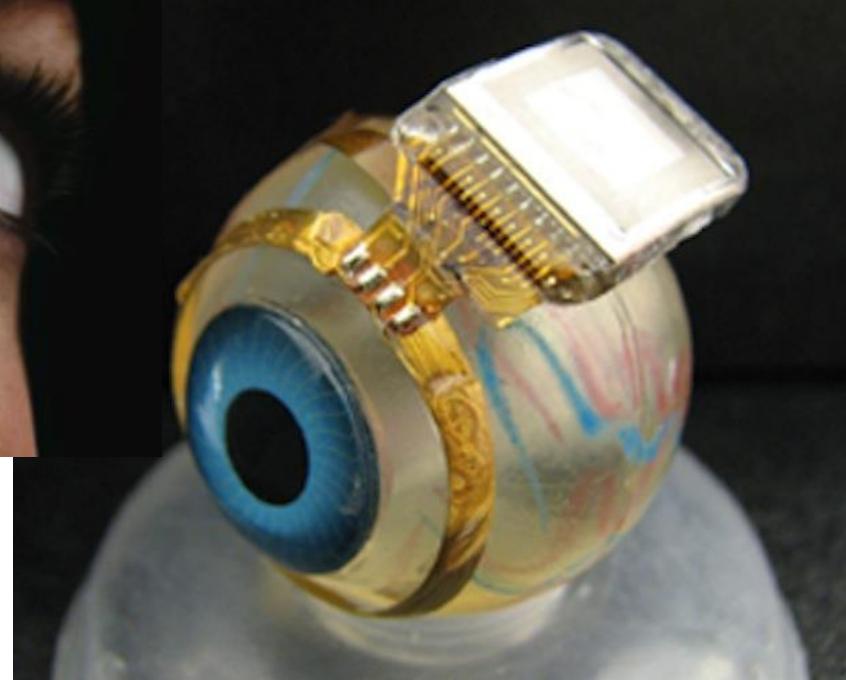
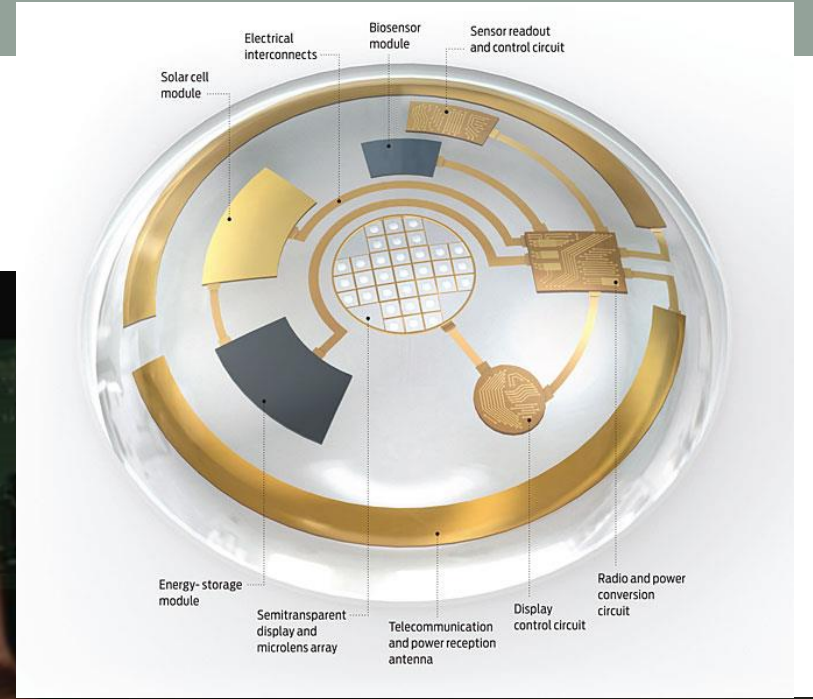

Integrated body computing

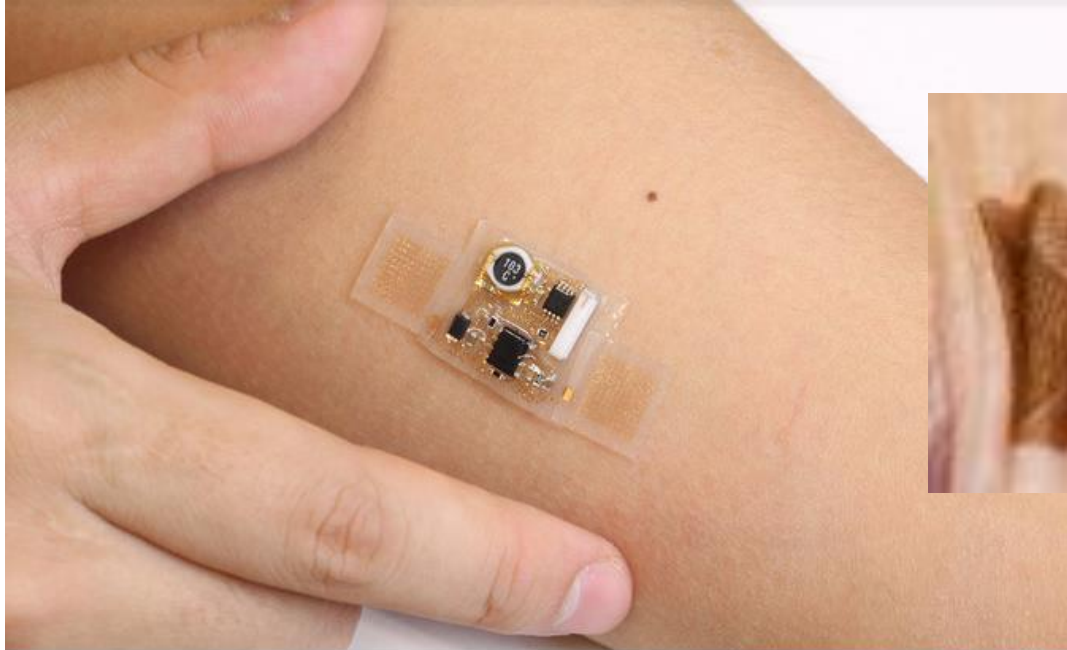

MC10 is working on attachable computers that look like small rectangular stickers and that can be placed on various parts of the body. John A. Rogers/The University of Illinois at Urbana-Champaign



Avatars & 3D Selfies

Start With: Home

A Premade Avatar
Select from one of the following premade avatars.



Your Own Photo
Create a clone of yourself or your friend.



Uplo

[for more options see the gallery...](#)
[...or start with a blank avatar](#)



Avatars & 3D Selfies



Avatars & 3D Selfies

We are immersed in our media today more than ever!

What will it be like in, say 100 years?

We will live in the realities we create



What are we creating, & Why?



Real & imaginary are about to enter a future dance in which they will whirl at such a velocity that we may have a hard time telling them apart.

The Future

The fluid realities of VR and AR are inspirational!

They are a forcing function for new generations to THINK about not only what constitutes our reality, but how all realities can, do and *will* affect us as human beings.





QUESTIONS?