



Memories of Tomorrow

Tom Coughlin, President
President, Coughlin Associates,
www.tomcoughlin.com

Biography

Tom Coughlin, President, Coughlin Associates is a digital storage analyst and business and technology consultant. He has over 37 years in the data storage industry with engineering and management positions at several companies. Coughlin Associates consults, publishes books and market and technology reports (including *Emerging Memories Poised to Explode: Emerging Memory Report*), and puts on digital storage-oriented events.

He is a regular storage and memory contributor for forbes.com and M&E organization websites. He is an IEEE Fellow, President of IEEE-USA and is active with SNIA and SMPTE. For more information on Tom Coughlin and his publications and activities go to www.tomcoughlin.com.



Outline

- Digital Storage and Memory Drivers
- Hard Disk Drives
- Flash Memory and Solid State Drives
- NVMe Storage Fabrics and Memory Centric Computing
- Persistent Memories
- Conclusions
- References

Digital Storage and Memory Drivers



Memory and storage needs are exploding

- Increasing storage demands—IDC 175 Zetabytes of data created by 2025 (31 ZB in 2018)
- New sources for unstructured data from media and entertainment, IoT, medicine, geo-science and big data
- Growth in local storage, storage at the edge (or the fog) and storage in large data centers (the cloud)
- There is a need for fast memory and storage to support processing and accessing this data and cheap storage to keep it for the long term

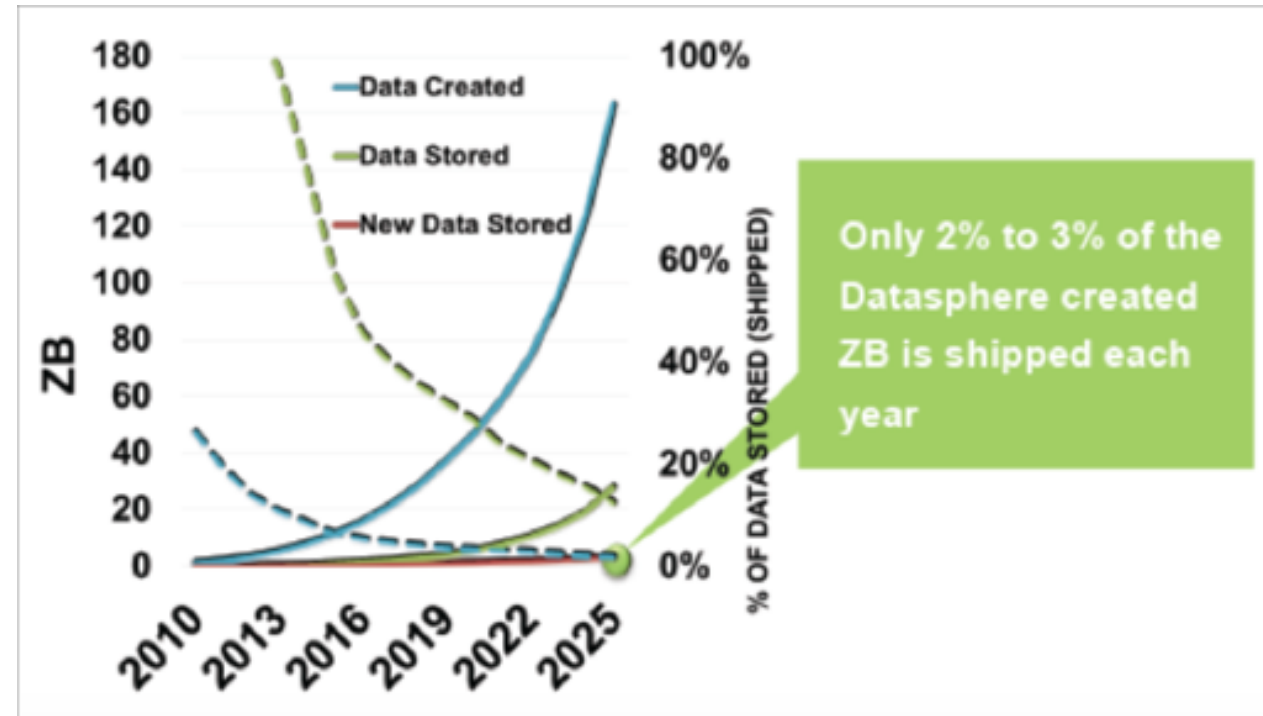

Example resolution, data rates and storage capacity requirements for professional media standards

Format	Resolution (width X height)	Frame Rate (fps)	Data Rates (MB/s)	Storage Capacity GB/Hour
SDTV (NTSC, (8-bit)	720 X 480	~30	31	112
HDTV (1080p, 8-bit) RGB	1920 X 1080	24	149	537
UHD-1 4K (10-bit) RGB	3840 X 2160	60	1,866	6,718
UHD-2 8K (12-bit) RGB	7680 X 4320	120	17,916	64,497
Digital Cinema 2K (10-bit) YUV	2048 X 1080	24	199	717
Digital Cinema 4K (12-bit) YUV	4096 X 2160	48	1,910	6,880
Digital Cinema 8K (16 bit) YUV	8192 X 4320	120	25,480	91,729

8K Ultra-HD may use more than 170X capacity of HD!

Exabyte Video Projects Coming?

- Video at 16,000 X 8,000 pixel resolution, 24 bits/pixel, 300 fps raw video content could require **115 GB/s data rates and 414 TB/hour**. If 4 cameras were used to create data for a 360 degree presentation, the raw data would be **1.66 PB for an hour of content**
- Within 10 years we could have pro-video projects generating close to an exabyte of data

Living the dream...

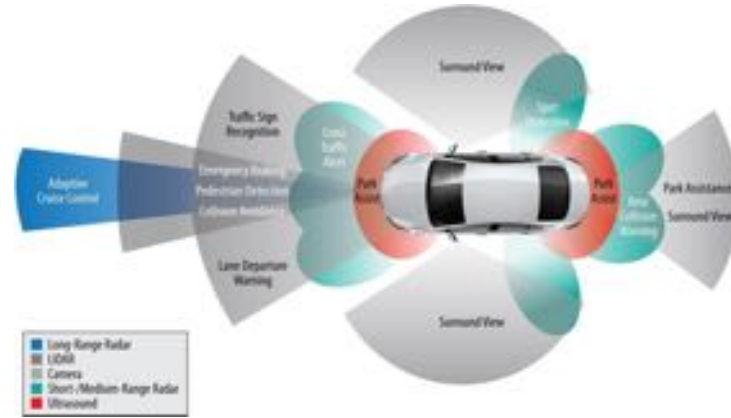

- Our personal devices are capturing more details of our lives than ever before and in greater details
- Our consumer electronics are connected to applications that can help us find our way, connect with others, maintain our health and make the world a better place
- In the future our cars may drive themselves, our homes make sure that we have what we need and our health and well being will be maintained by intelligent machines and applications

Autonomous Cars = Big Data

(Source: DataFloo, <https://datafloq.com/read/self-driving-cars-create-2-petabytes-data-annually/172>)

- Google autonomous car generates about 1 GB/sec. Avg. US driver drives 600 hr/year. This would generate 2 PB/car/year.
- The number of cars worldwide will surpass 1 billion
- So the potential size of data generated by autonomous cars is huge
- Most of the resulting long term storage is in the cloud, which also does the bulk of analytics

IOPS by Storage Technology/Interface

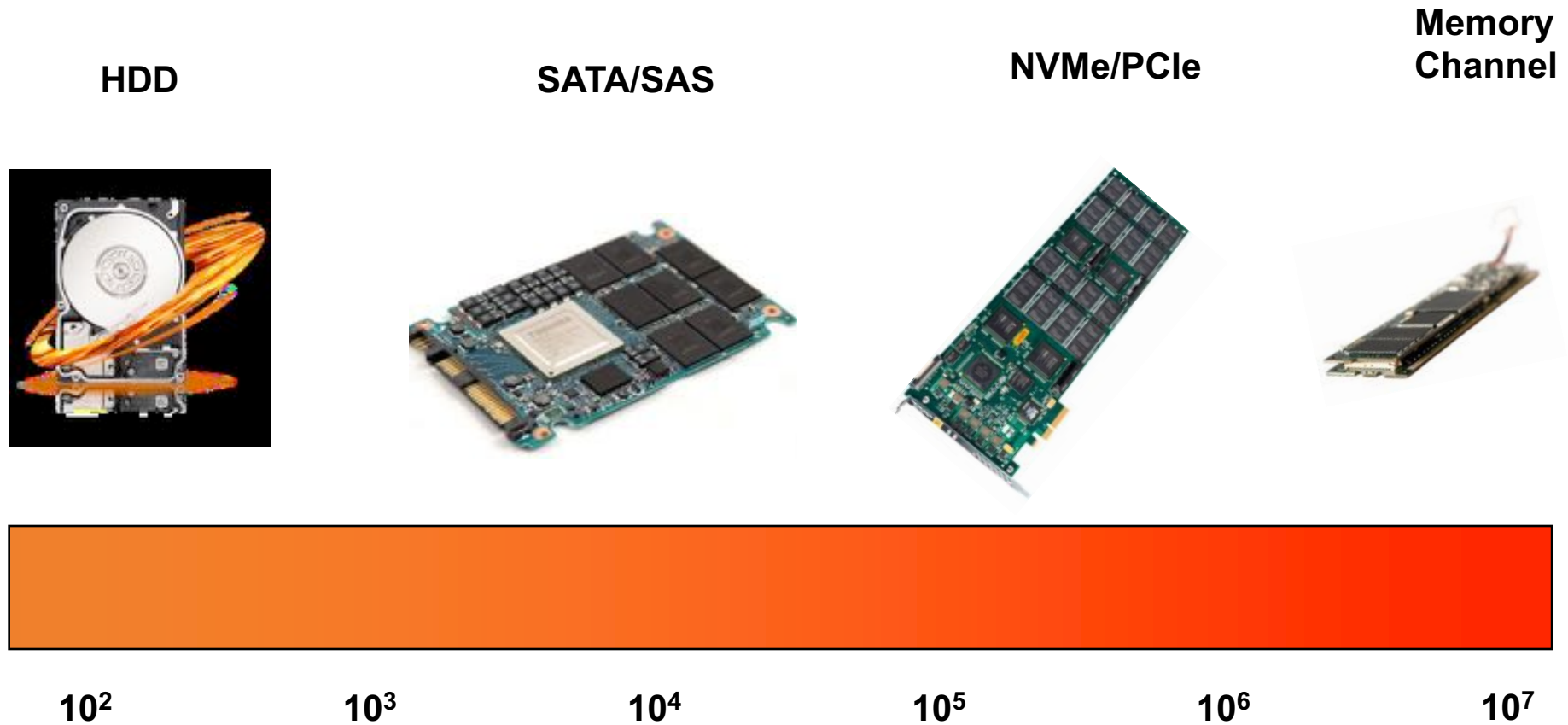

Digital Storage and Memory Tiering

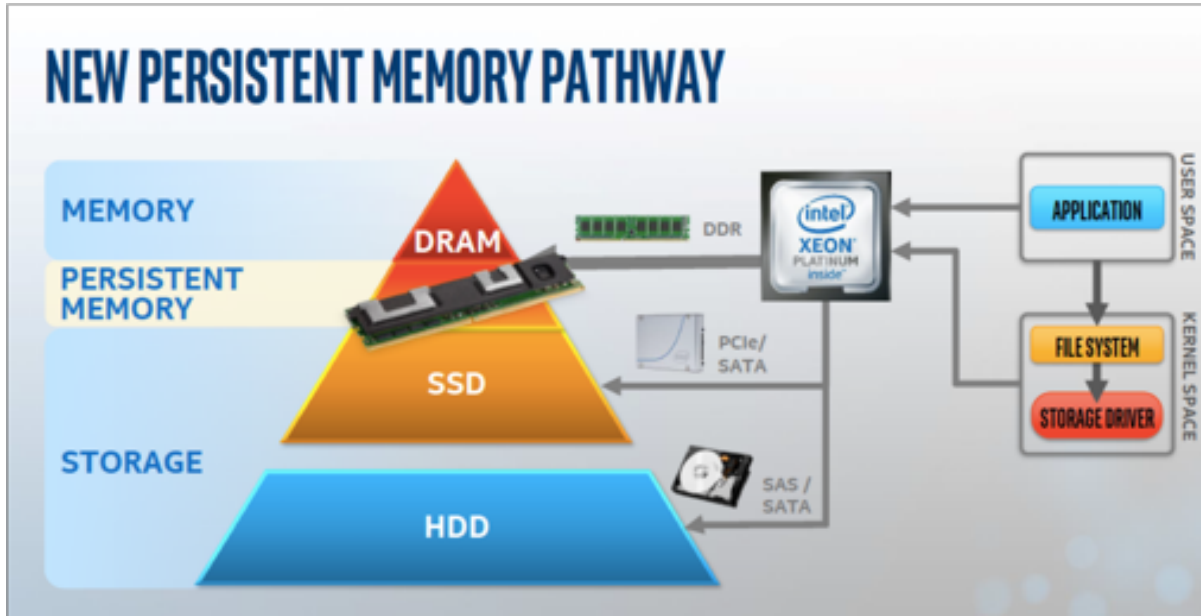

Intel Optane DIMM Announcement, June 2018

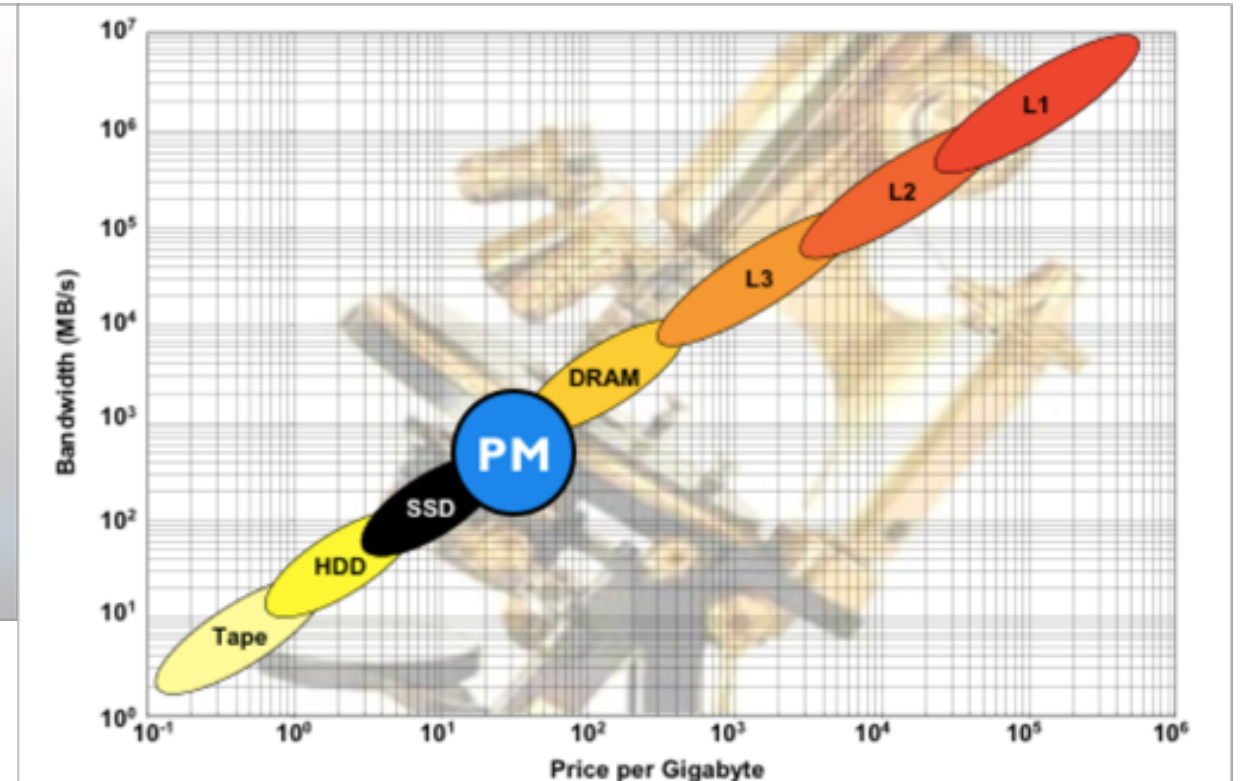

2018 Emerging Memories Report, Coughlin Associates, www.tomcoughlin.com

A photograph of an open hard disk drive (HDD) showing its internal components. The central feature is a large, circular, silver-colored platter. To the right, the actuator arm is visible, with a white head stack assembly (HSA) mounted on it. The HSA has the number "001115" printed on it. The drive is housed in a black plastic casing. The text "Hard Disk Drives" is overlaid in the center of the image.

Hard Disk Drives

Hard disk drives

- Currently shipping up to 16 TB with 20+ TB expected by 2019, 40+ TB by next decade
- Current HDD areal densities exceed 1 Gb per square inch
- He-filled HDDs provide greater energy efficiency and less cooling requirements
- Fastest growth in HDDs is for bulk cold storage in data centers
- Besides magnetic tape and optical discs, HDDs are the most cost effective storage medium for colder data



HDD Projections by Application High, Median & Low Estimates

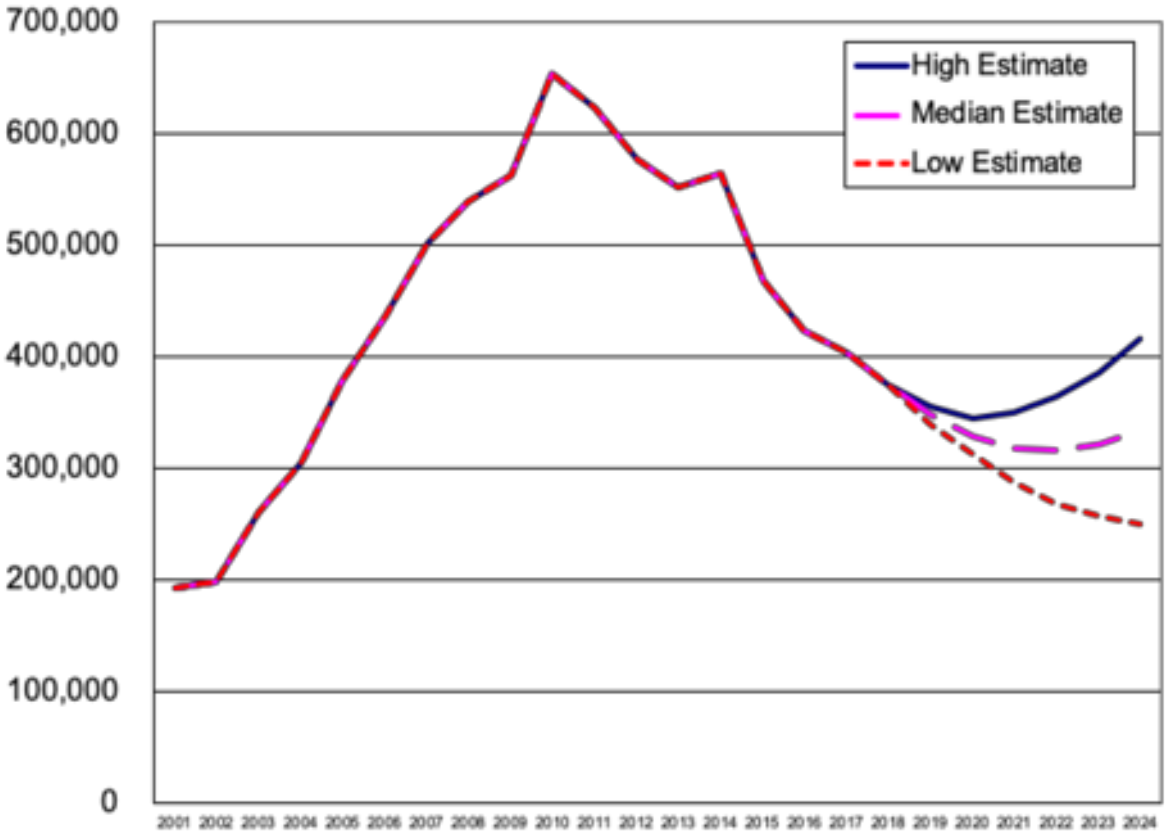
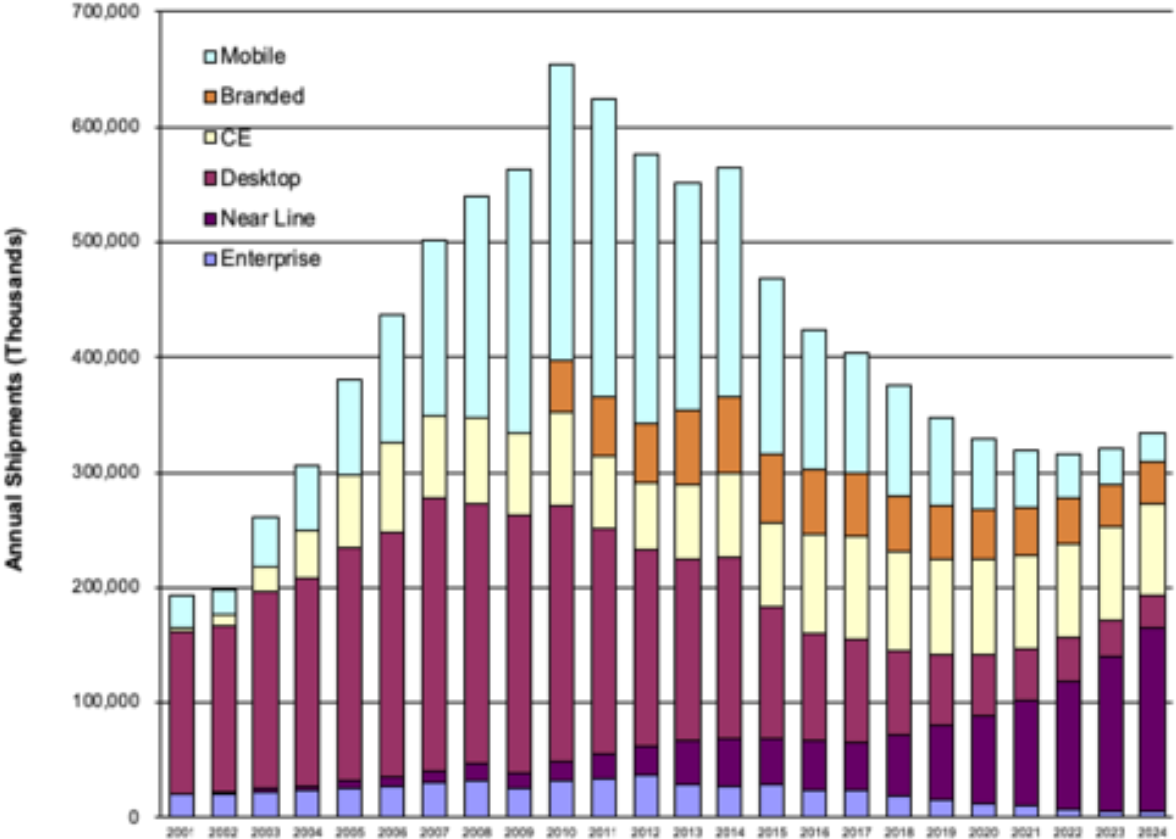

Western Digital Projections

- WD projects data center growth in SMR HDDs
- Plans MAMR drive shipments in 2019 (16-18 TB)
- WD demoed a dual actuator prototype at the OCP Conference in San Jose
- Seagate says that they will ship dual actuator drives for qualification in 2019

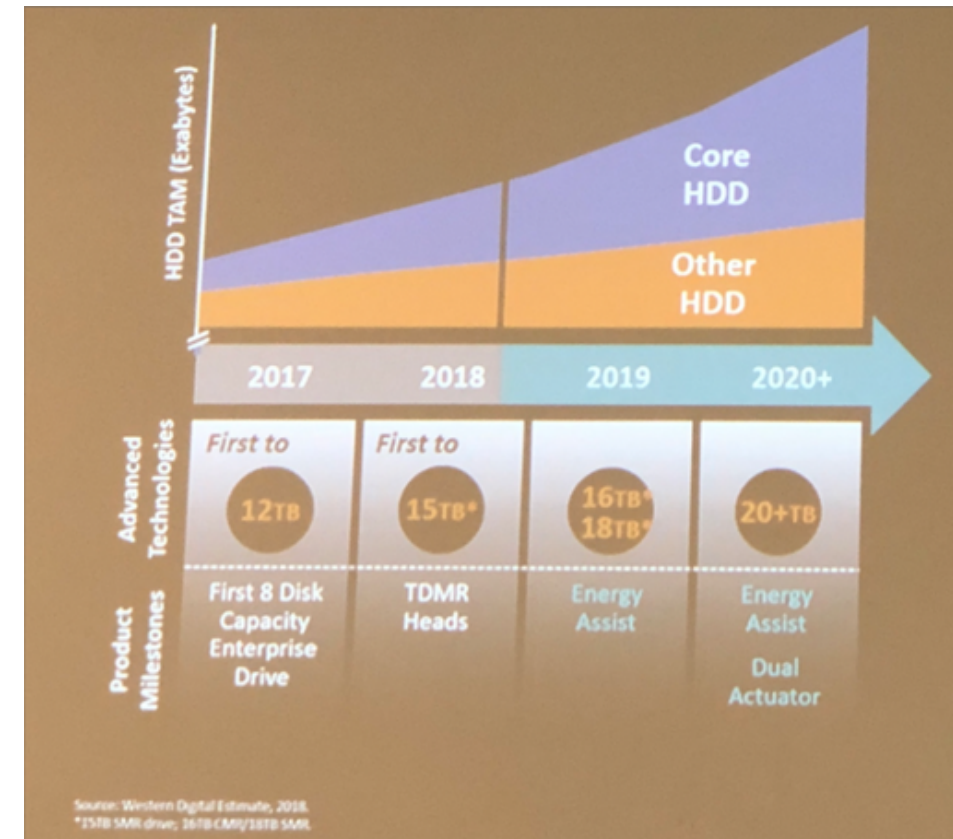
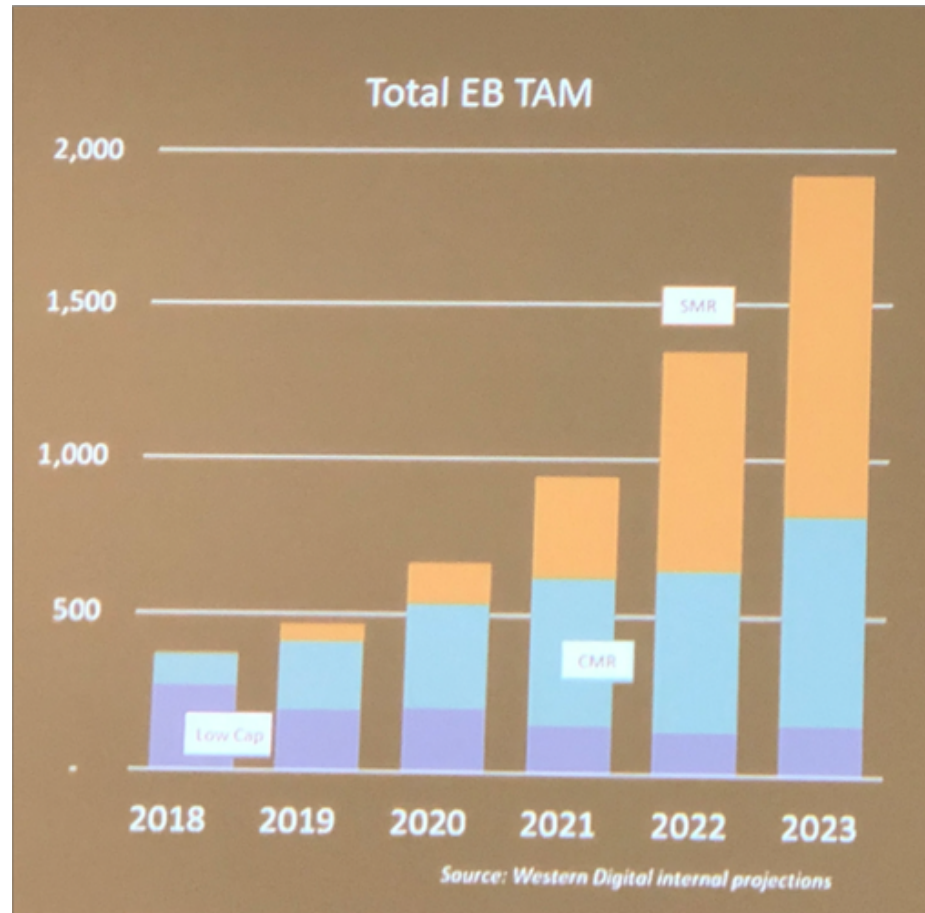

HDD Technology Roadmap (ASTC)

- Perpendicular Magnetic Recording (PMR) technology has nearly reached its limit in areal density, near 1.2Tbpsi.
- Seagate plans to introduce 16 TB 3.5-inch form factor HAMR HDDs as well as HDDs with two actuators (to speed up data transfers to and from the HDDs) in 2019.
- Western Digital has said that they will produce MAMR HDDs with higher storage areal densities in 2019 as well.
- These two companies have indicated that energy assisted recording will allow them to achieve HDDs with 20 TB by 2020 and 40 TB in the next decade.
- Toshiba announced a 16 TB 3.5-inch He-filled PMR drive in early January 2019.

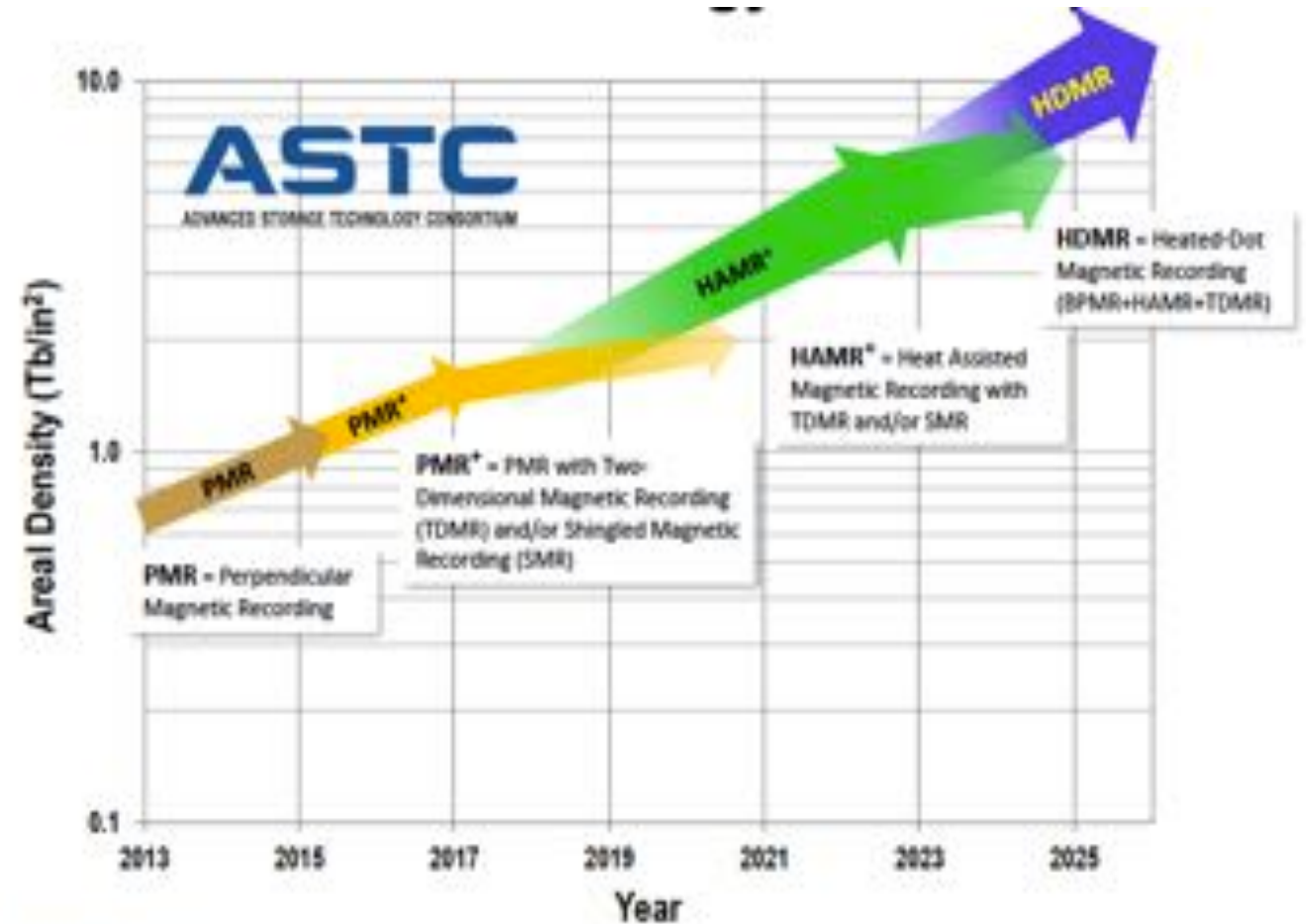

IDEMA

ASTC Proprietary

A close-up, slightly blurred photograph of a dark grey or black integrated circuit (chip) mounted on a printed circuit board. The word "FLASH" is printed in white, sans-serif capital letters on the surface of the chip. The background shows other components and traces on the board, but they are out of focus.

Flash Memory and SSDs

Flash Memory



- Flash memory is increasing in storage capacity (density) and decreasing in \$/GB pricing but still more expensive than HDDs
- Flash memory is winning more applications as its price (\$/GB) drops
- Development of NVMe and NVMe-oF has enabled better access to the performance capabilities of flash memory
- In many data center applications, flash memory is now the primary storage
- Flash Memory can also handle more rugged environments, making this a favored storage media for remote location—such as for edge storage

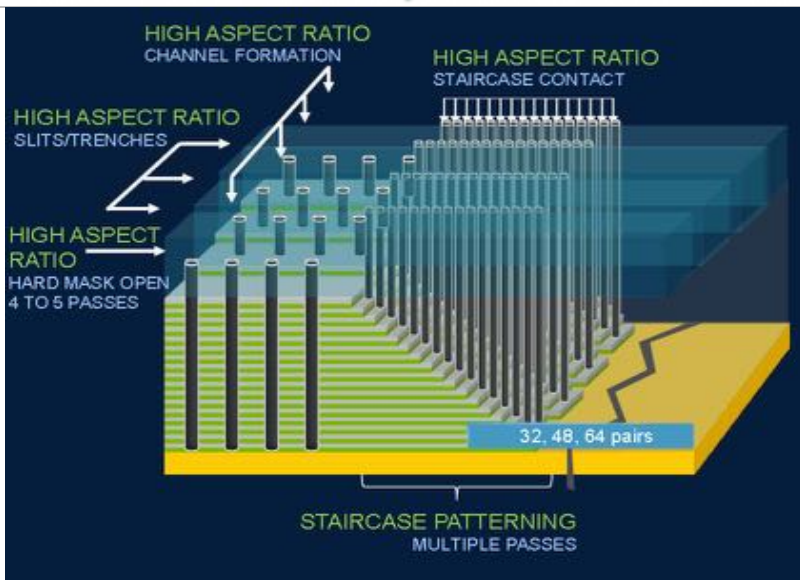

NAND Flash Expectations

- New 3D flash fab exceeded planar production in 2018, easing supply constraints
- This has resulted in a drop in flash prices in 2018 (2019 and 2020 will see further NAND Flash price declines)
- Currently flash memory vendors are shipping 64-layer 3D flash in volume and will ramp up 96-layer NAND flash later in 2019 (1 Tb/die)
- Projections are that 3D flash could go out many generations—500+ layers!
- The price reductions for 96 layer and higher will be less than going to 64 layer, because of slower wafer process speeds

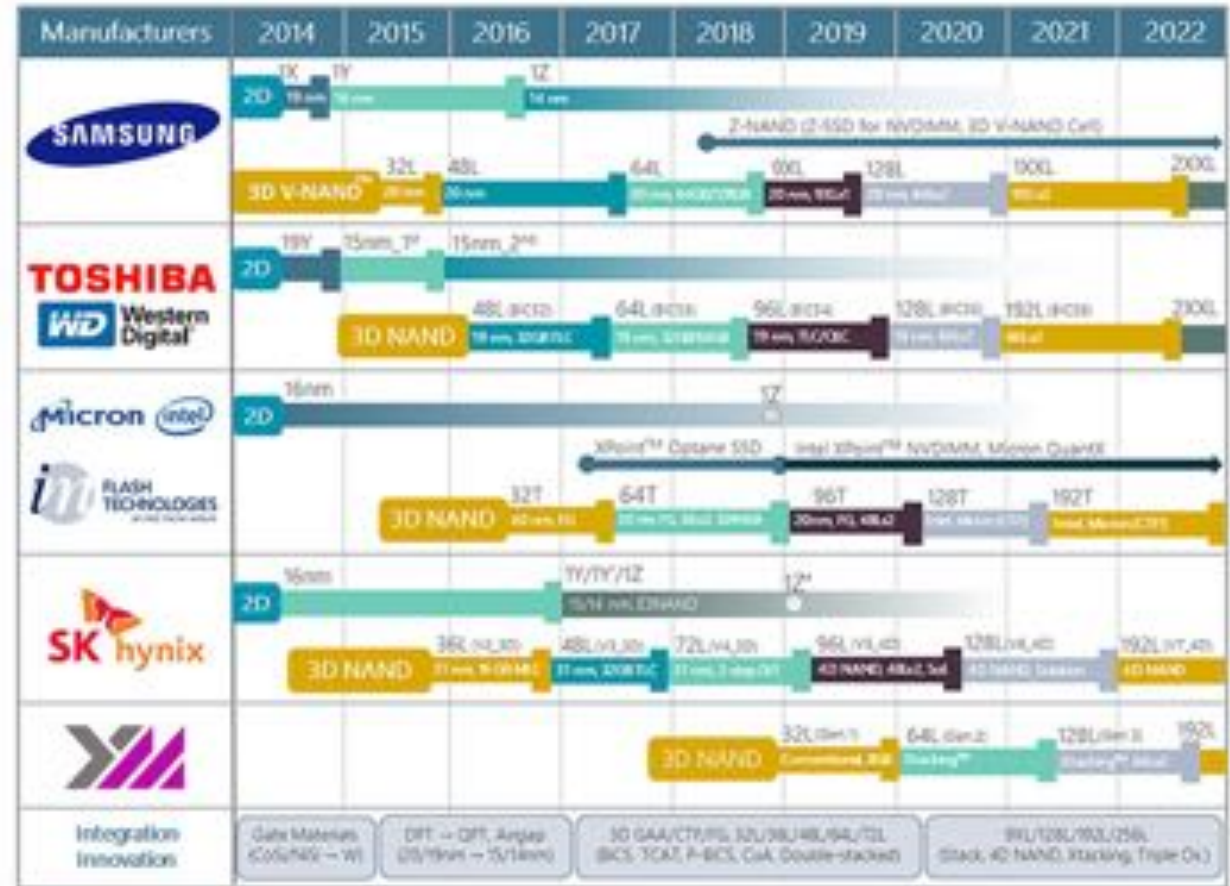

Movement to 4 bits/cell for some applications

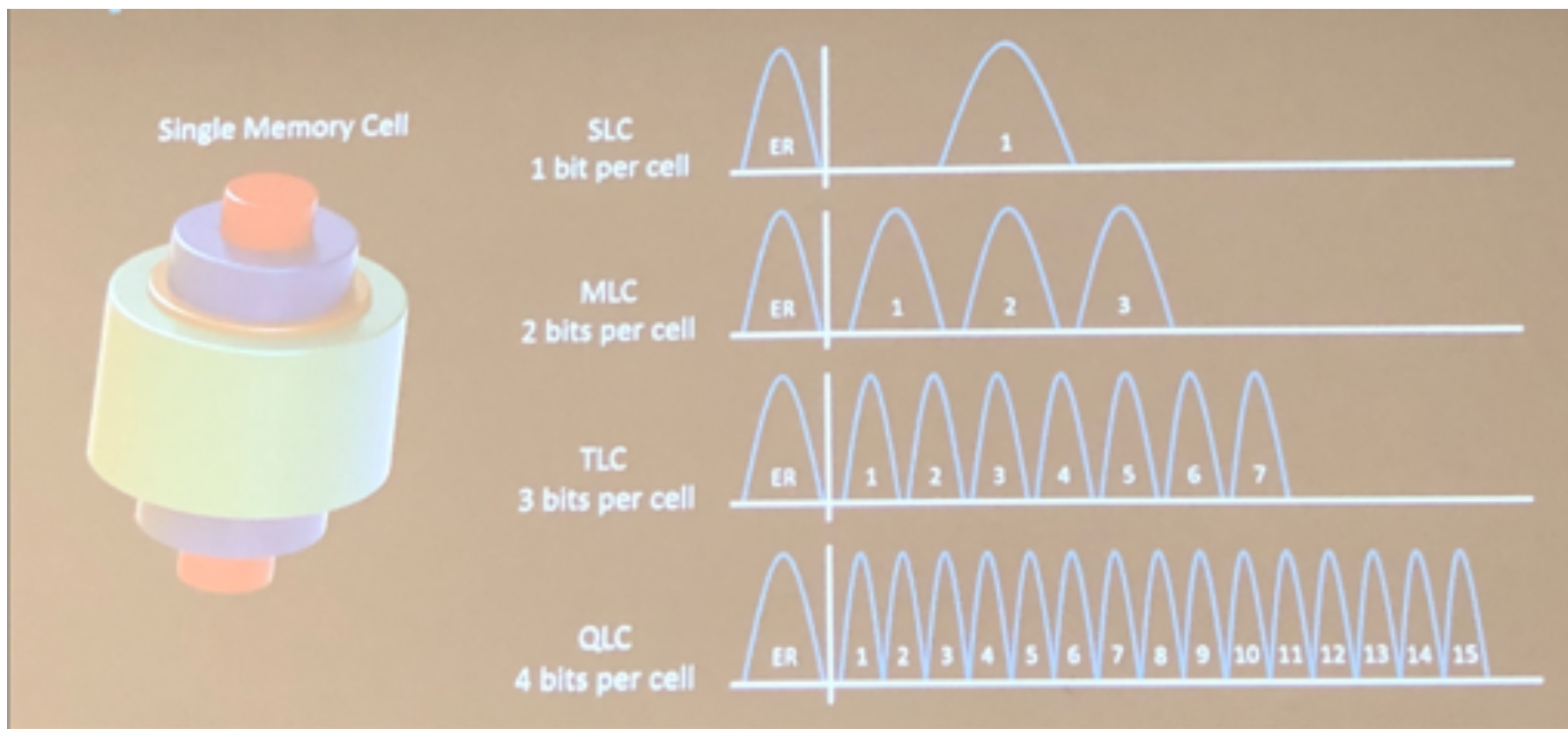

- WD/Toshib 96-layer 3D NAND has 70nm minimum feature size
- This enables relatively durable 4 bit cells
- Also different parts of die can have different cell configurations (e.g. SLC and QLC)

3D Scaling and Performance Flash

- 3D scaling is a function of manufacturing cost
- At ISSCC Conference WD announced a 126 layer 3D NAND
- WD/TMS, like Samsung are looking at performance optimized flash to compete against Intel/Micron's 3D XPoint

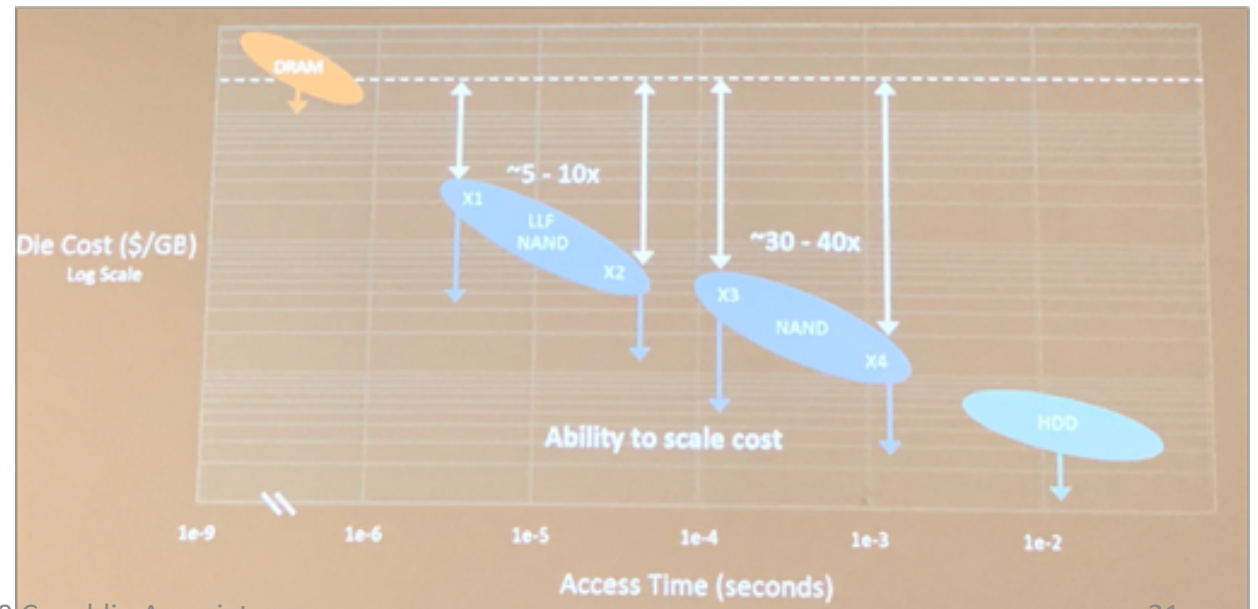
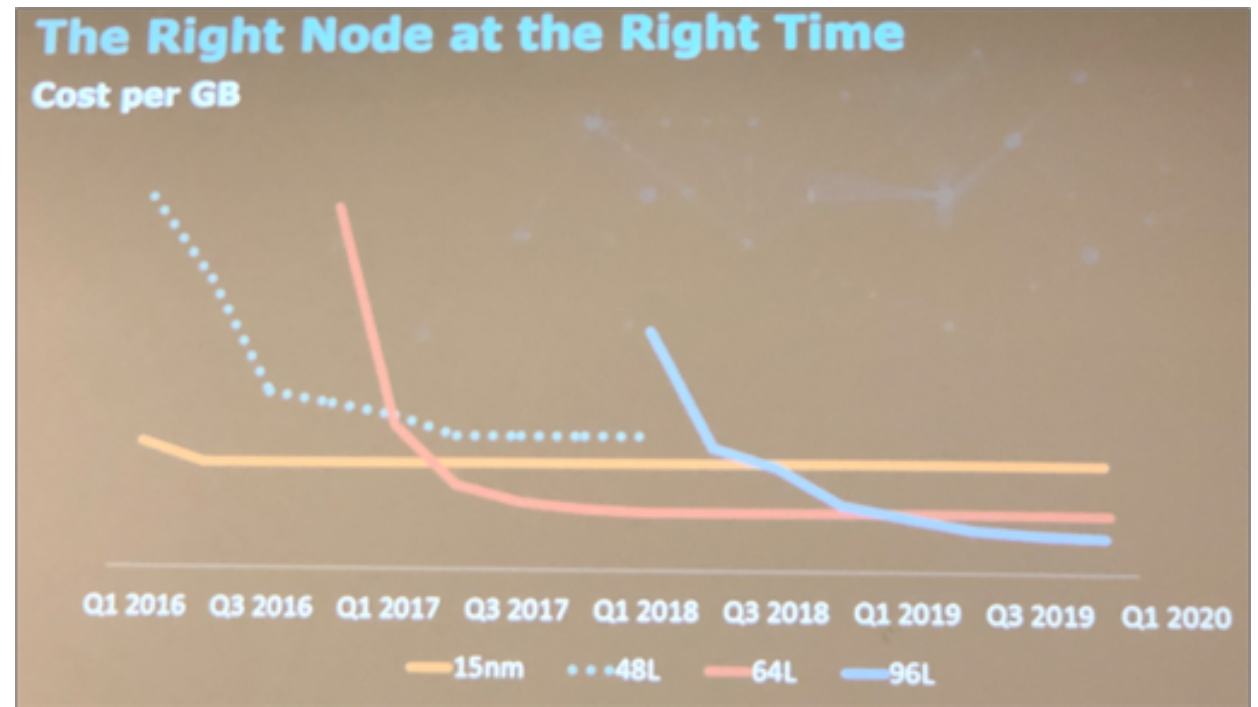

Comparison of SSDs and HDDs

- SSDs provide faster read and write speed (bandwidth or throughput) and lower latency (time to get data from when it is requested) than HDDs.
- As a consequence of their speed, SSDs can complete more operations (e.g. reading or writing information) per second (IOPS). SSDs generally consume less energy than HDDs, which usually continue to spin the disks in the HDD even when data is not being written to or read from the magnetic disks.
- SSDs are also more rugged than HDDs and are less susceptible to damage or data loss from vibration and shock. Thus; SSDs have higher bandwidth, lower latency, lower energy consumption and are more rugged than HDDs

Raw Average Storage HDD and SSD Prices

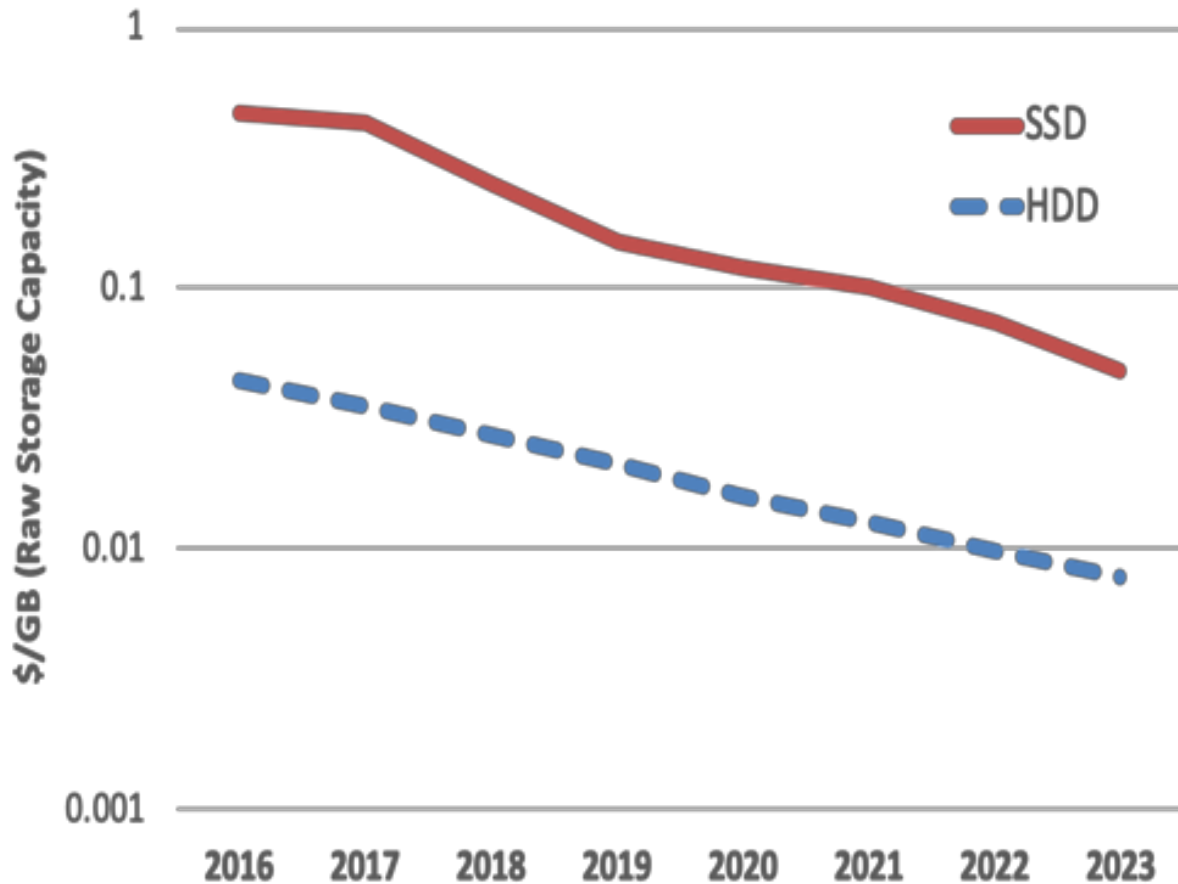

- While the HDD shipped volumes have declined, prices per GB for HDDs have continued to decrease (although somewhat slower than in the past due to slower areal density growth), as compared to SSDs
- With the introduction of HAMR and MAMR HDDs in 2019 the decline in HDD \$/GB prices can continue, roughly paralleling the increase in NAND flash chip capacities and thus the decline in NAND flash (and thus SSD) \$/GB.
- Currently HDD prices per GB can be as low as \$0.03 while NAND Flash prices per GB (raw capacity) can be as low as \$0.25 (about 8 X higher than HDDs).

NVMe Storage Fabrics and Memory Centric Computing

CONTRIBUTORS TO NONVOLATILE SOLID-STATE STORAGE LATENCY

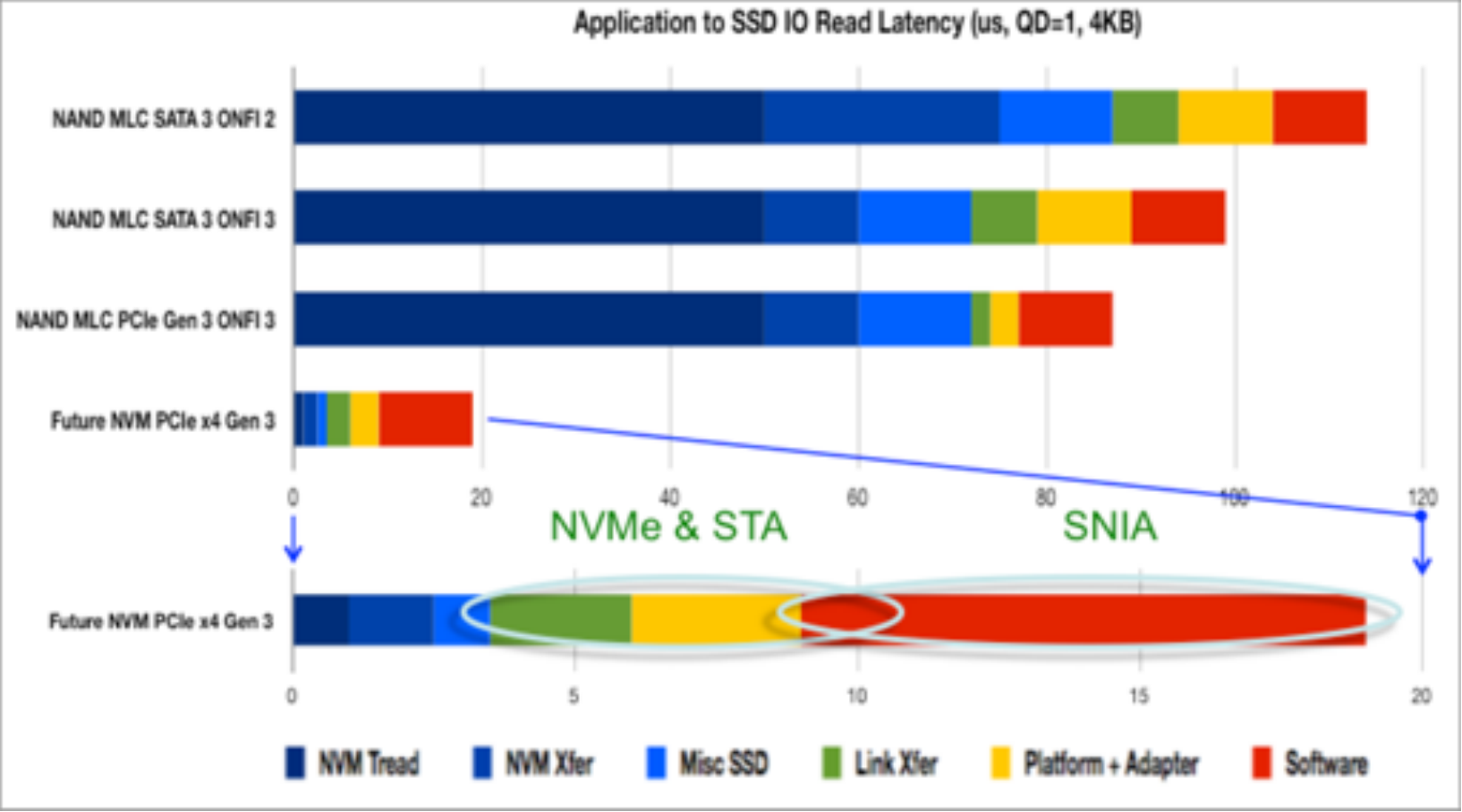

Source: Storage Networking Industry Association (SNIA),

PM Needs New Software

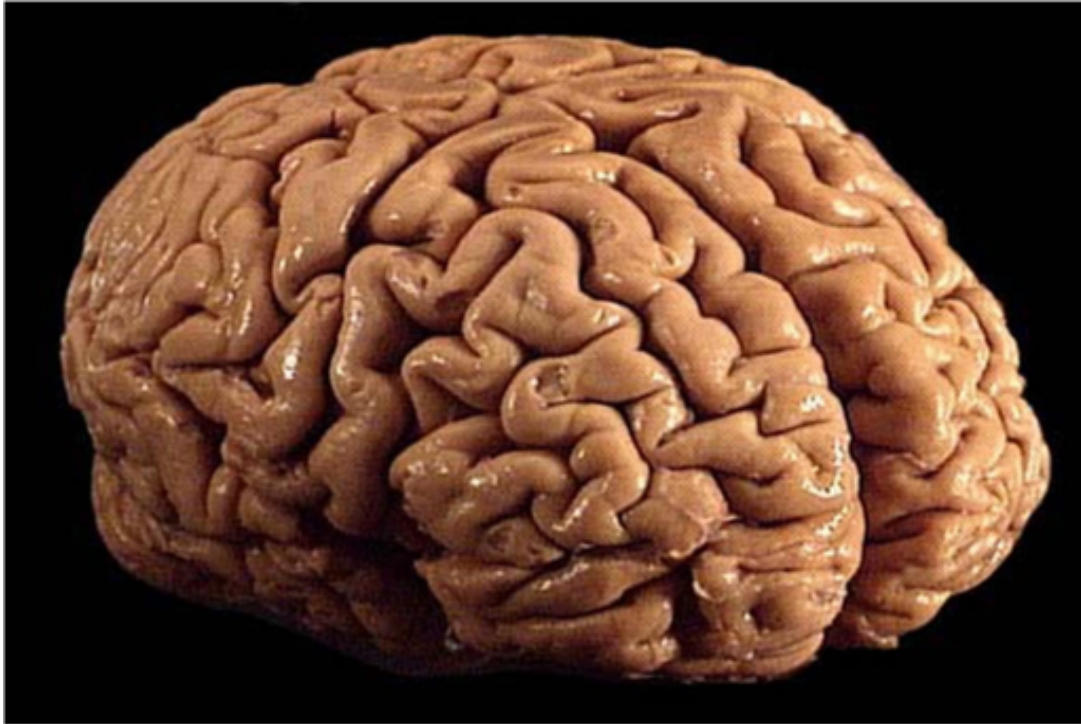

- Move away from “Storage vs. Memory” approach
 - Store at the byte level, not blocks
 - Avoid the storage stack
 - Avoid things like flash translation

NVMe Roadmap

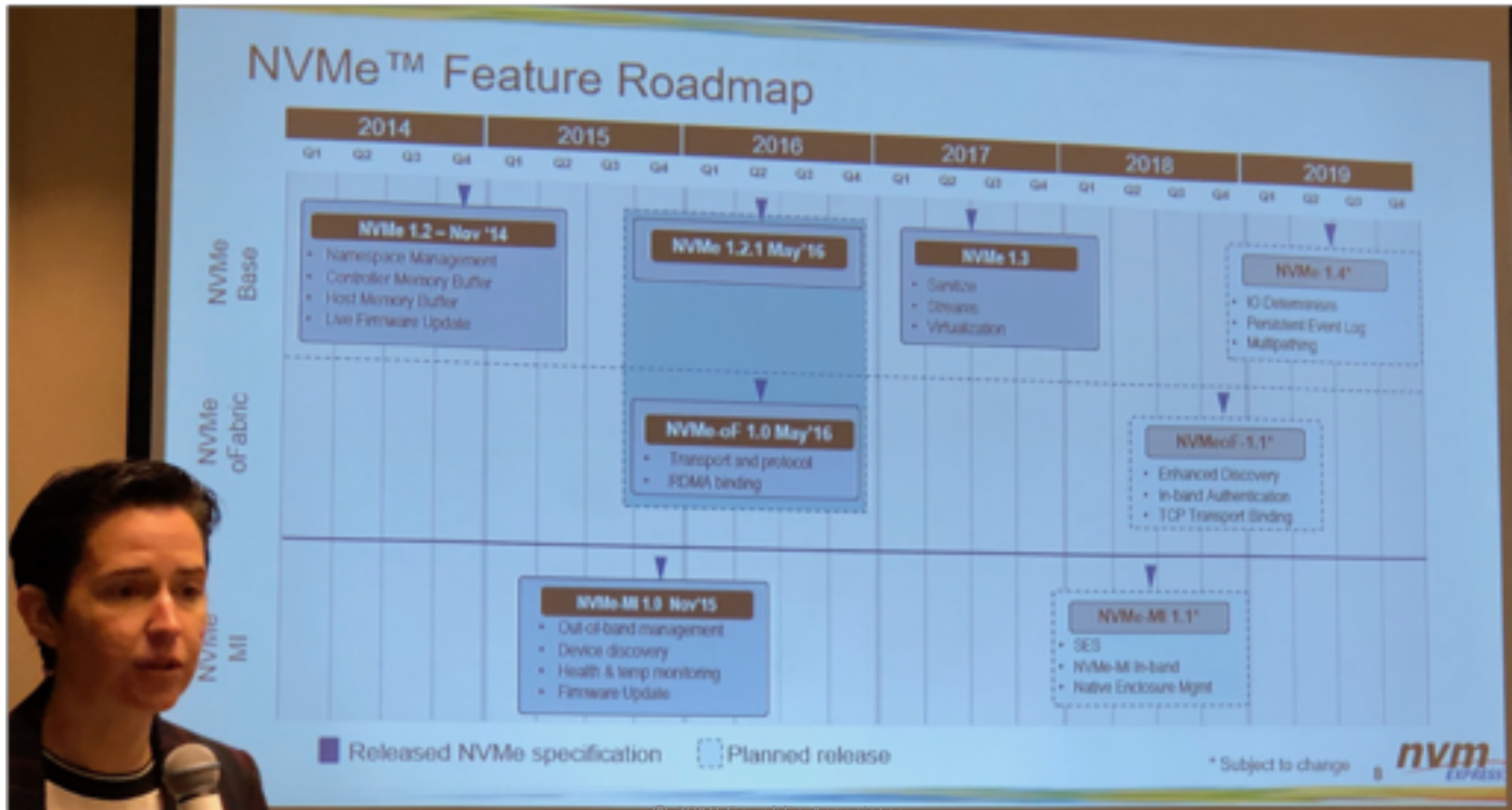

NVMe over Fabric

- Mellanox announced their BlueField SoC for accelerating NVMe over Fabrics (200 Gb/s of throughput and more than 10 million IOPS in a single SoC device)
- A French company, Kalray released a high-performance NVMe-oF target controller for enabling NVMe-based (JBOF) array boxes.
- 2018 and 2019 saw introductions of many NVMe over Fabric products

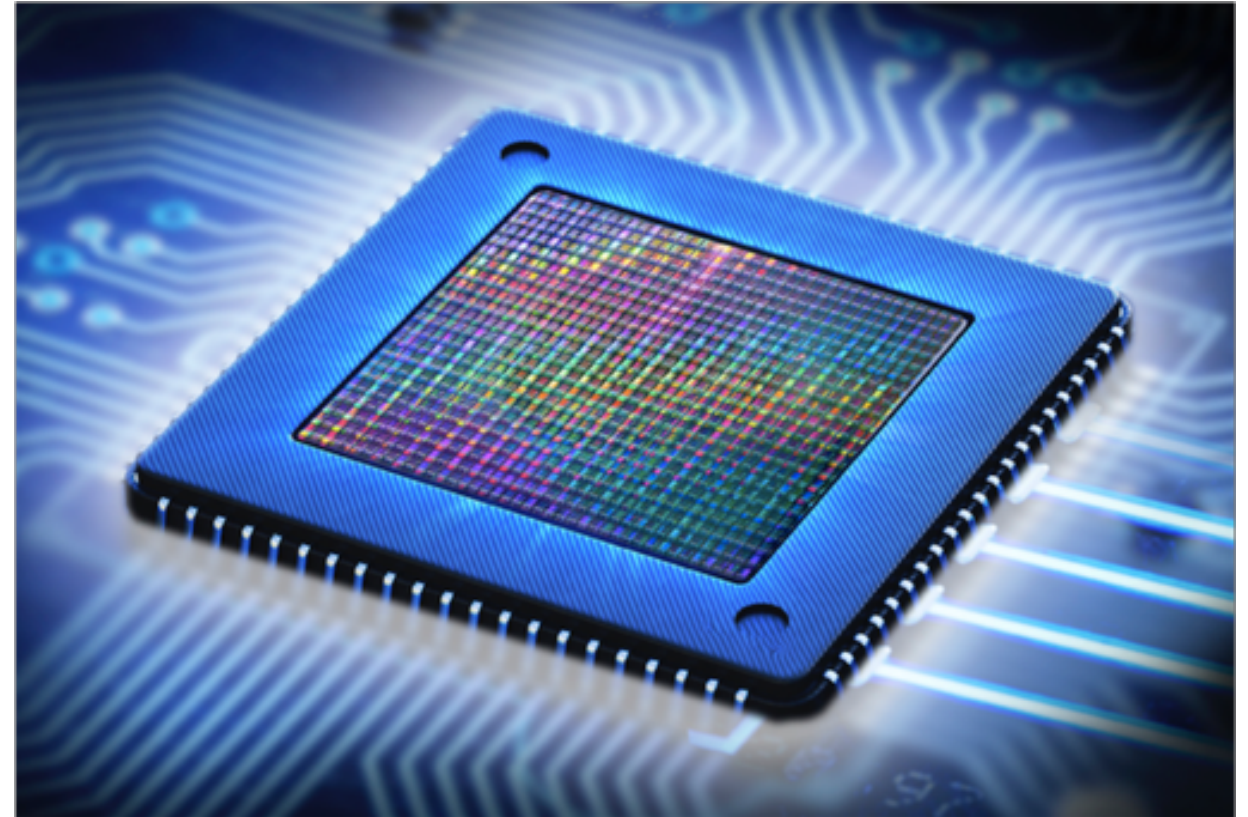

What is Computational Storage? SNIA has Defined the Following

Computational Storage Drive (CSD): A component that provides persistent data storage and computational services

Computational Storage Processor (CSP): A component that provides computational services to a storage system without providing persistent storage

Computational Storage Array (CSA): A collection of computational storage drives, computational storage processors and/or storage devices, combined with a body of control software

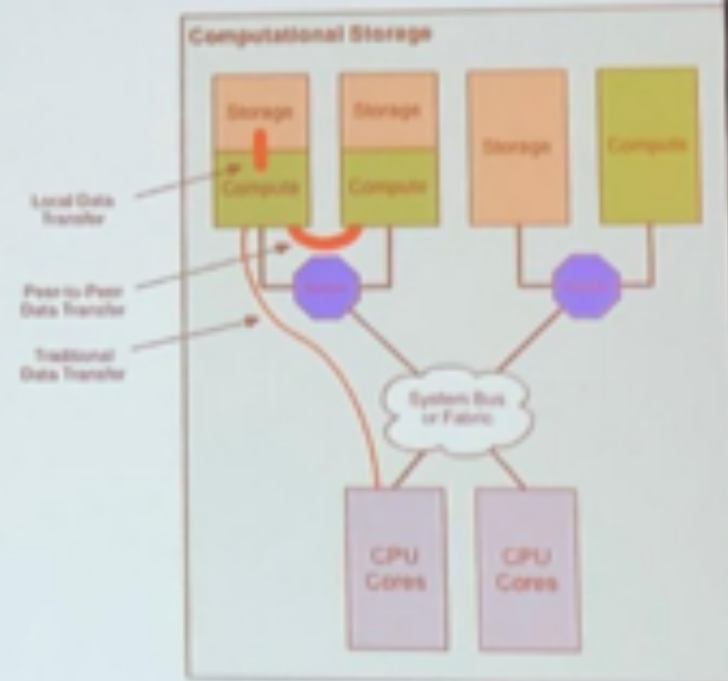

NVMe™ Computational Storage

- NVMe based **Computational Storage Processor (CSP)** advertises zlib compression.
- Operating System detects the presence of the NVMe CSP
- Used by the device-mapper to offload zlib compression to NoLoad.
- This can be combined with p2pdma to further offload IO.
- With standardization this can be vendor-neutral and upstreamed.

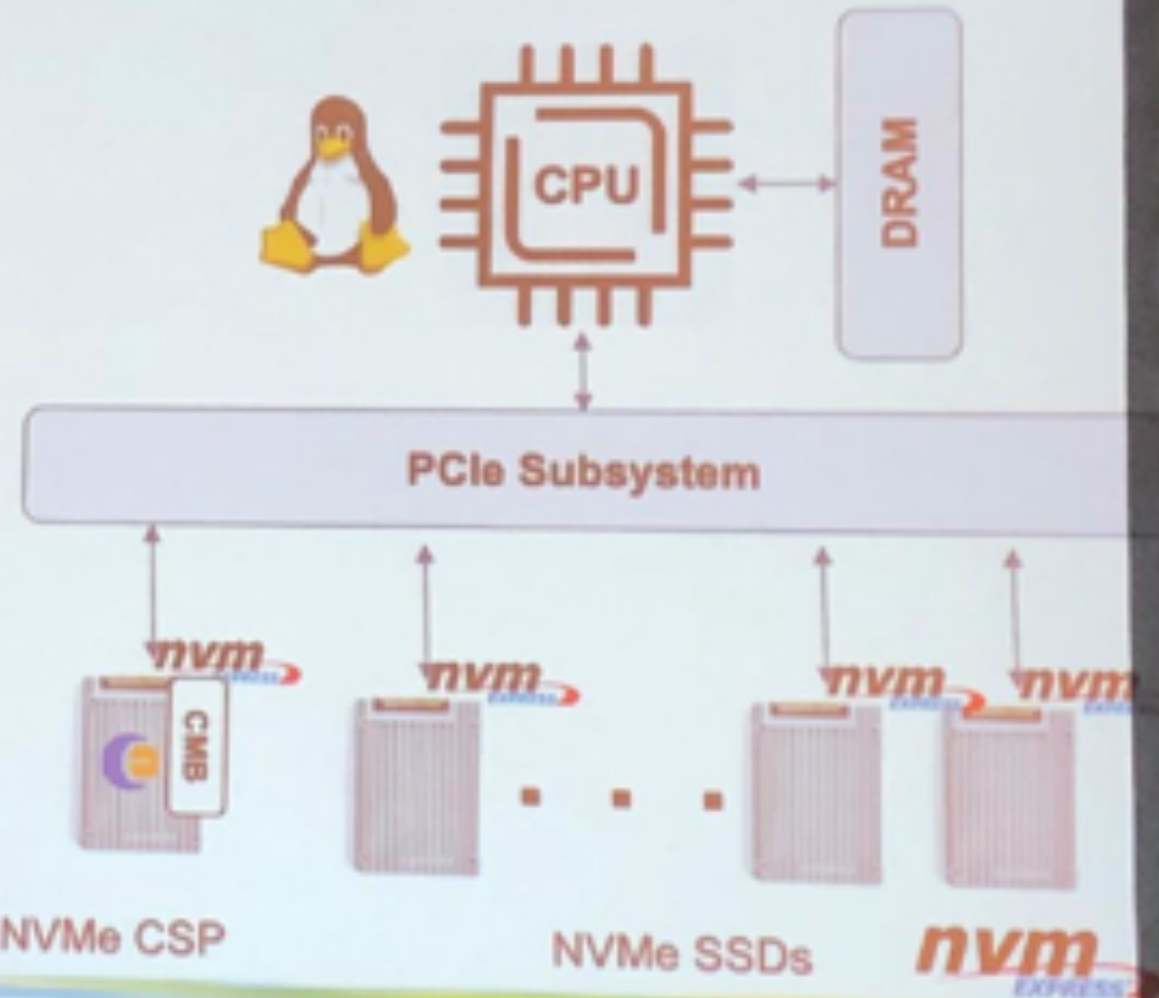

There are many paths to Computational Storage

FPGA to Multi-SSD

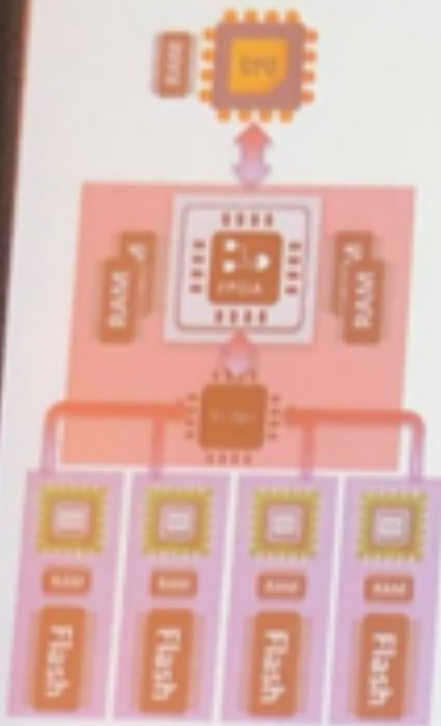

FPGA/SSD Controller

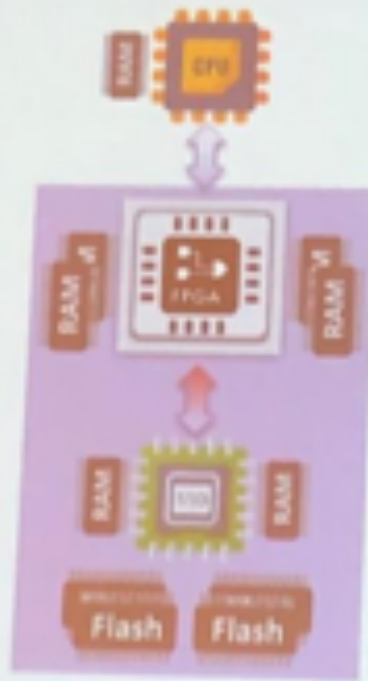

FPGA Only

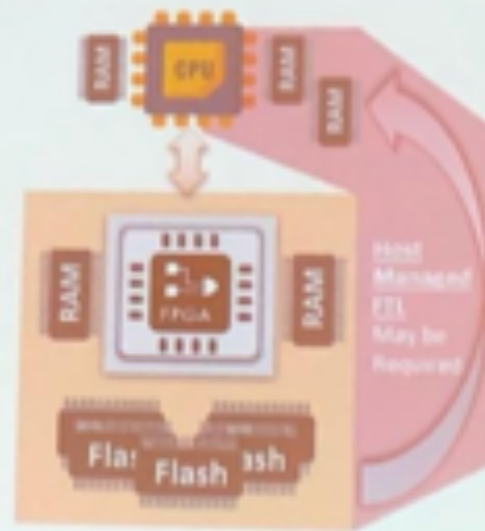

SINGLE ASIC Solution

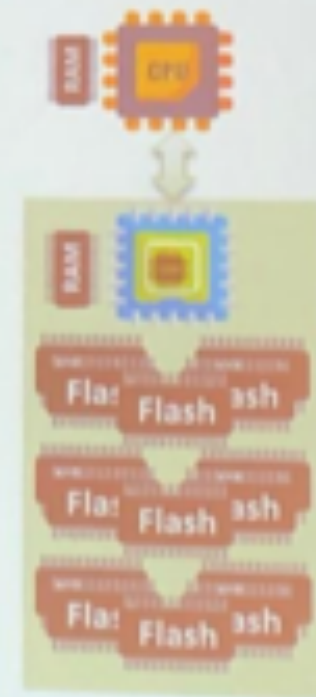

Memory-centric Computing

For many emerging challenges, memory capacity, memory access latency and memory bandwidth are more constrained than compute resources

- **Memory Disaggregation**
Remove memory from behind the processor
- **Memory Pooling & Sharing**
Enable efficient use of memory. Address new class of problems with large memory footprint
- **Heterogeneous Compute**
Enable multi-vendor heterogeneous compute (e.g. ML accelerators)

2018



CPU-centric architecture

2020

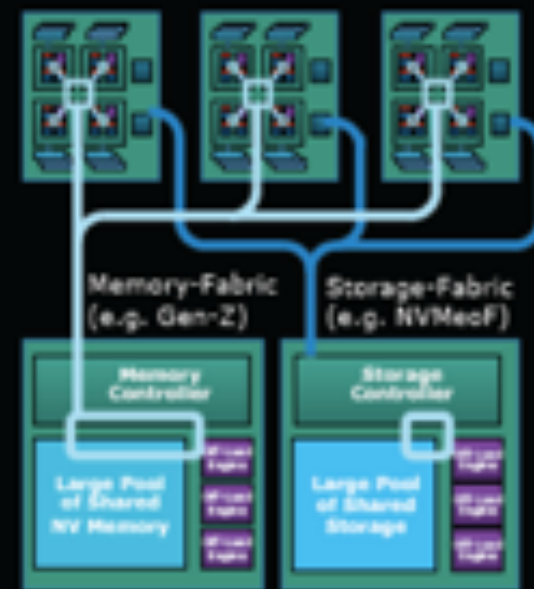

Data-centric architecture

NVMe Storage Systems for Edge and Data Center

- PCIe based NVMe storage interfaces will be the basis of future storage systems architectures using flash-based solid state drives
- This includes network storage capabilities including Remote Direct Memory Access (RDMA) and fabrics running the NVMe protocol, NVMe-oF
- Currently products available running over fibre channel, IB and Ethernet

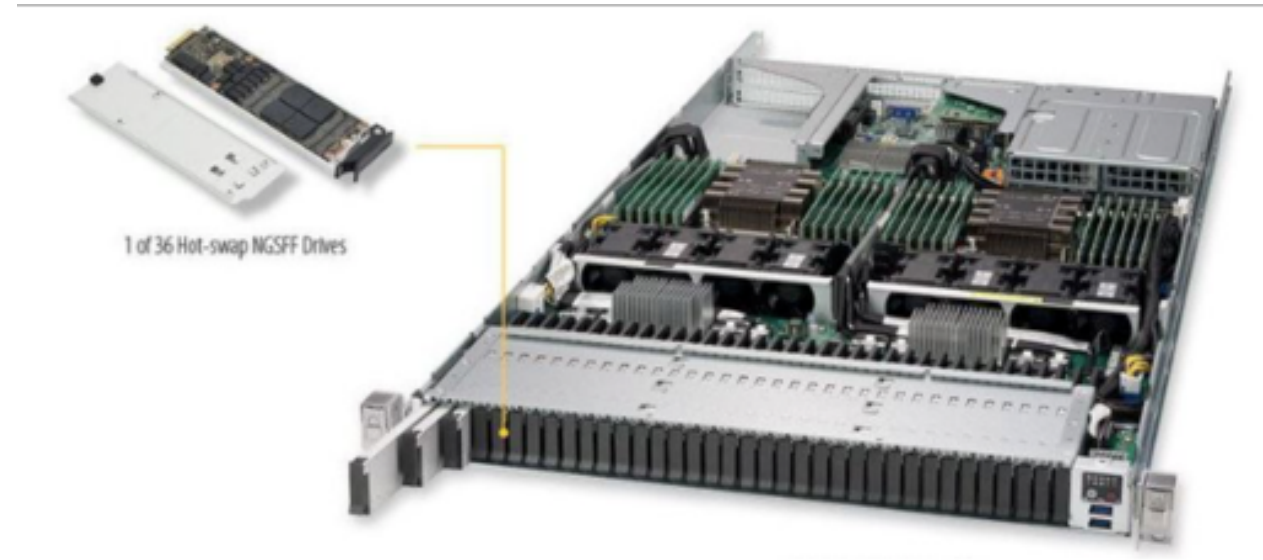

Evolving the Data Center

SATA to NVMe™ transition

Data Center SSD Revenue by Interface¹

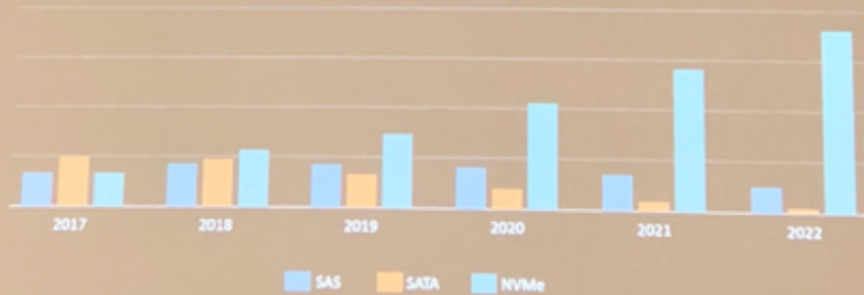

Evolution of the Data Center

- NVMe will be the de-facto interface going forward due to scalability (multiple PCIe lanes) and lower latency (even shows up for HDD array in WD Openflex)
- WD line of storage systems includes HDD to flash storage
- Composable infrastructure delivers real time resource allocation

Expansive Portfolio of Platforms and Systems

Spanning Enterprise, Private-Cloud, and Edge Data Centers

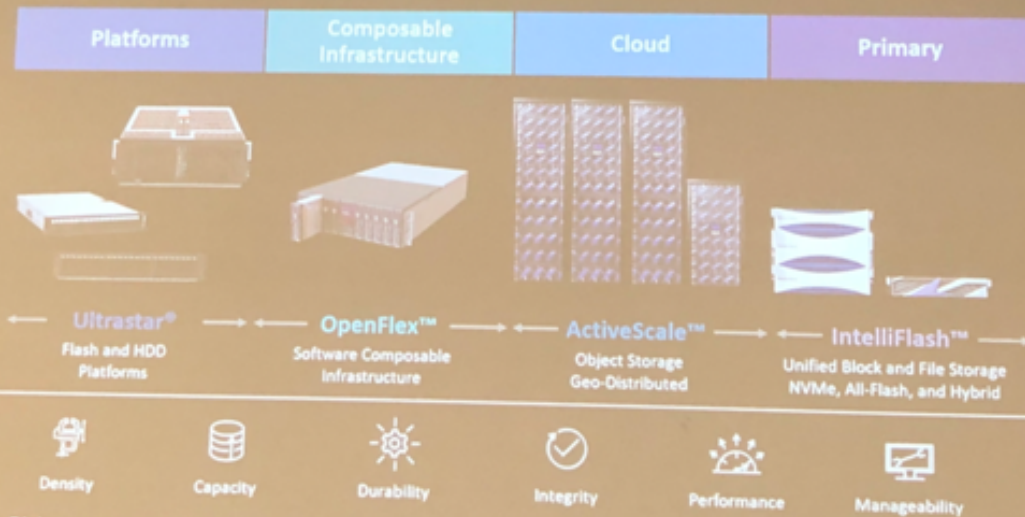

NVMe over Fabric and Decomposable Storage

- Shared decomposable storage using NVMe over Fabrics (including Ethernet)
- Ultimately this sort of decomposable infrastructure could include compute and storage/memory on the same fabric, enabling computational storage
- Also storage with computation can do tasks freeing up the central processor(s)

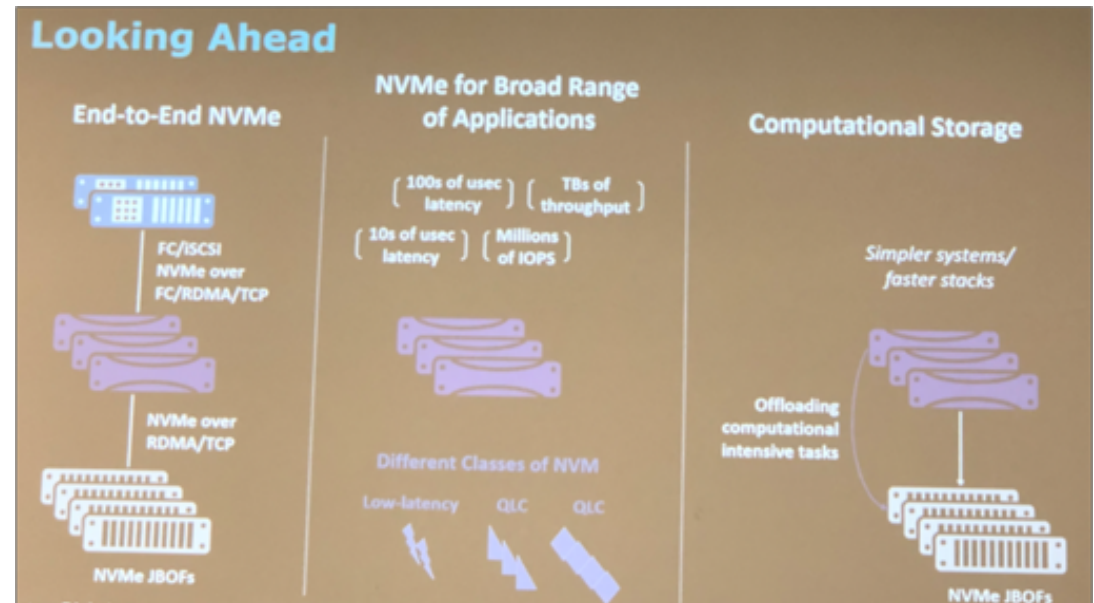
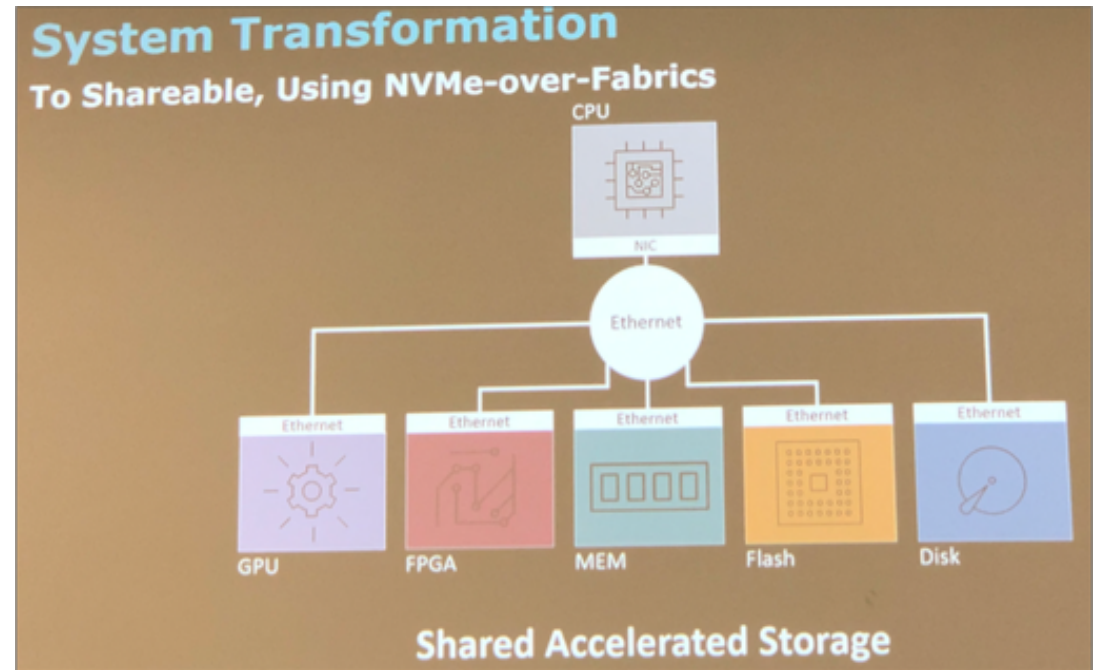

Storage Capacity Shipments for LTO Tape, SSDs and HDDs

- The growth and processing of data will lead to the use of many types of digital storage
- SSDs will dominate for high performance storage and higher total revenue
- HDDs will be high capacity and used for colder storage
- Magnetic tape will be used by some organizations for the lowest cost (currently <1 cent/GB)

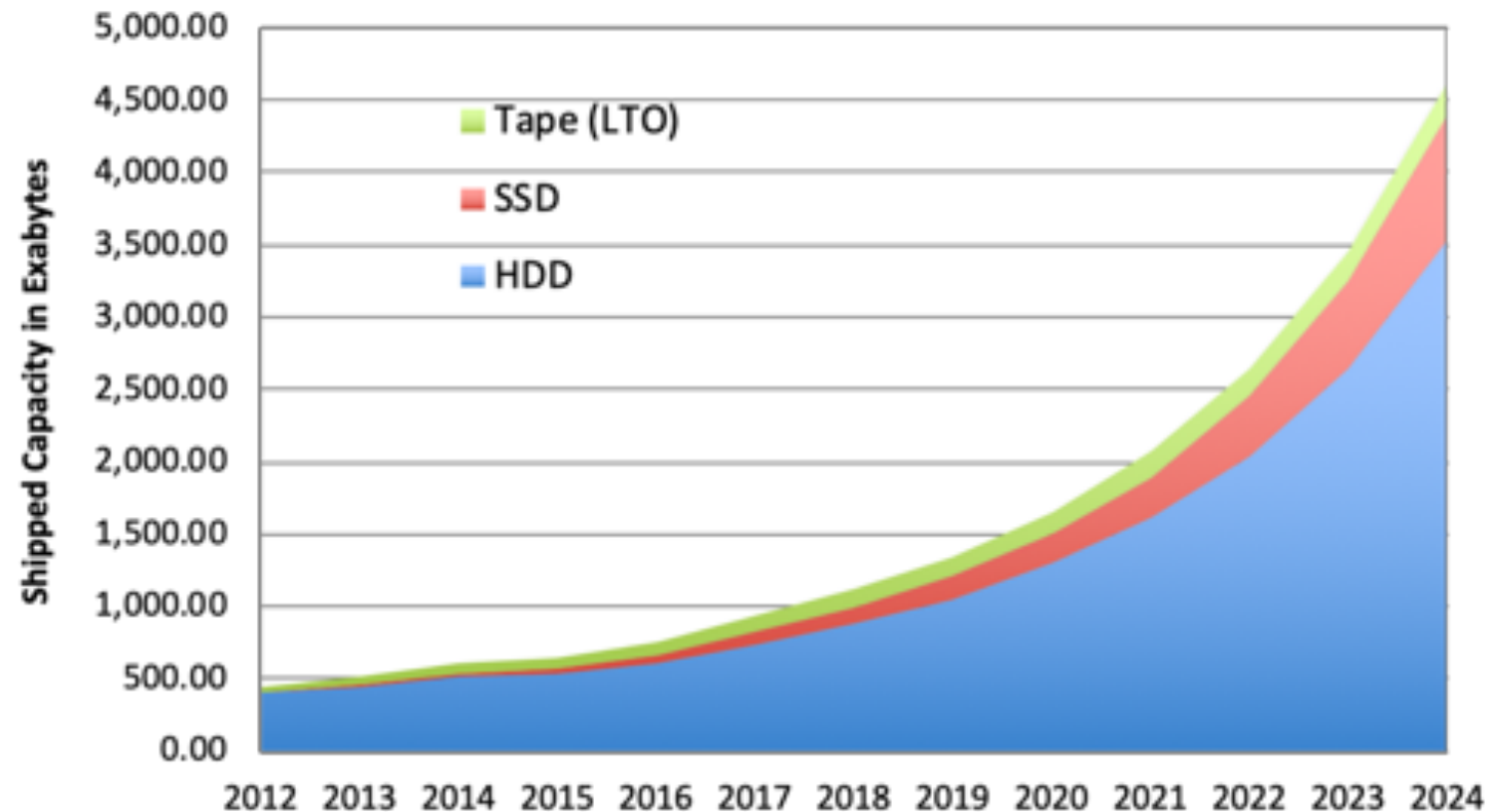

Persistent memory types

MRAM

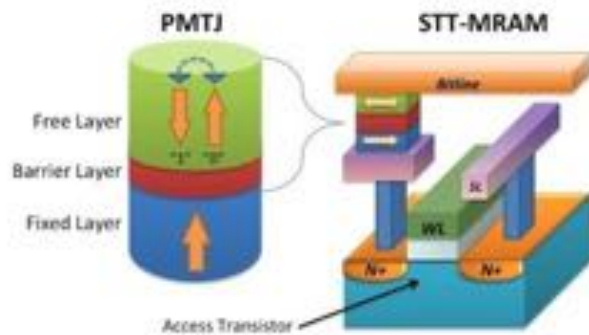

ReRAM

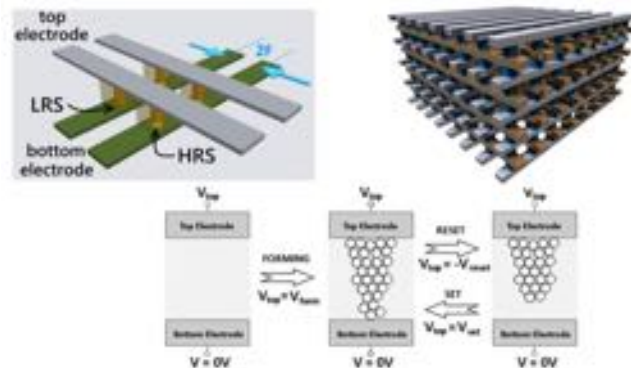

PCM

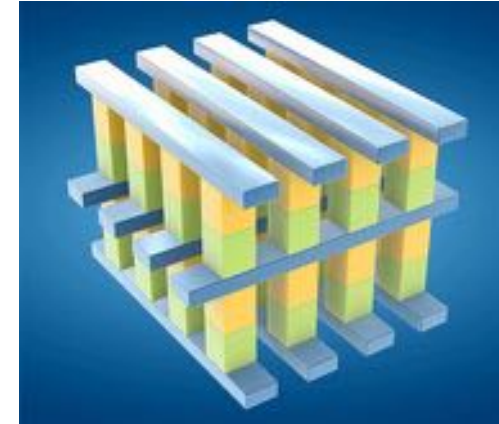

FRAM

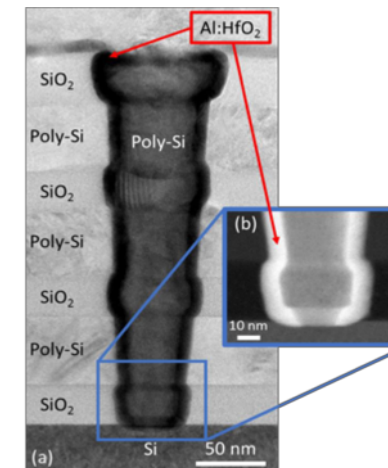

SOLID-STATE Memory/Storage Technologies

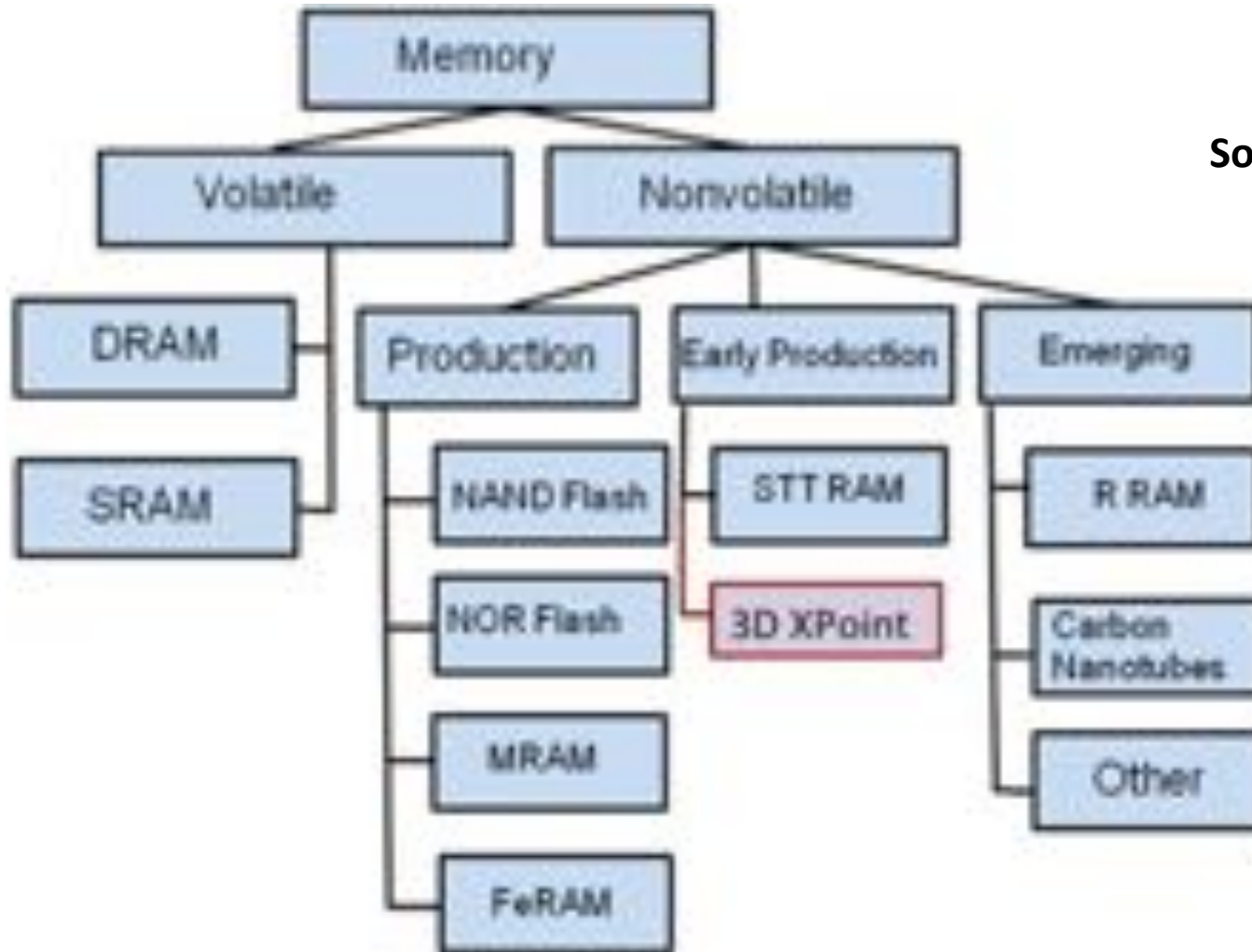

Source: Coughlin Associates, 2018

Why Emerging Memories are Necessary

- Flash can't scale with process advances
 - NAND flash went 3D at 15nm
 - 3D is not cost-effective in a CMOS logic process
 - NOR scaling stops with FinFET
 - 28nm & smaller processes need something new
- Low DRAM densities load down the memory bus
- AI is expensive on a von Neumann machine, hence new computer architectures

Emerging Non-Volatile Memories

- There is intense effort to commercialize several non-volatile memories that could replace current volatile memories, such as DRAM and SRAM
- These technologies can be applied to stand alone memory chips as well as in embedded memory
- This could reduce energy expenditure in battery and low power devices and also create more efficient data centers
- These NV memories will enable both IoT devices as well as data centers at the edge or in the cloud
- The memory technologies under consideration include magnetic random access memory (MRAM), resistive RAM (RRAM or ReRAM), phase change RAM (PRAM) and ferroelectric RAM (FRAM or FeRAM)

Comparison of Solid State Memory Technologies

	Established Memory Types				Emerging Memories				
	SRAM	DRAM	NOR Flash	NAND Flash	FRAM	ReRAM	Toggle MRAM	STT	PCM
Nonvolatile?	No	No	Yes	Yes	Yes	Yes	Yes	Yes	Yes
Cell Size	50-120F	6-10F	10F	4-5F	16-32F	4-6F	16-32F	6-7F	5-8F
Read Time	1-100ns	30ns	10ns	50ns	20-50ns	10-20ns	3-20ns	3-15ns	5-20ns
Write Time	1-100ns	50ns	10 ⁴ -10 ⁷ ns	10 ⁴ -10 ⁶ ns	50ns	20ns	10-20ns	3-15ns	>30ns
Endurance	=	=	10 ⁵	10 ³	10 ¹²	10 ⁵	10 ¹¹	10 ¹¹	10 ¹²
Write Energy	Low	Low	High	Med	Low	Low	Somewhat High	Low	Low
Write Voltage???	None	2	6-8	1.8	2-3	1.2	3	1.5	1.5-3

Source: Coughlin Associates, 2018

Other Emerging Memory Technologies

- Carbon Nanotubes
- Graphene Memories
- Conductive Electron RAM (CeRAM)
- Polymeric ferroelectrics
- Ferroelectric tunnel junctions (FTJ)
- Ferroelectric FETs (FeFETs)
- Interfacial PCM/TRAM
- Magnetoelectric RAM (MeRAM)
- Racetrack Memory

MRAM and PRAM

- MRAM

- Everspin shipped over 70 M MRAM Chips. Company has partnership with Global Foundries, who is building 300 mm wafers and targeting embedded memory applications
- Samsung and other foundries--plans to ship STT MRAM product samples by 2018/2019.
- IBM was showing an Everspin MRAM write cache for an SSD at the 2018 MRAM Developers Conference

- PRAM

- Intel Optane NVMe products shipped in 2017.
 - Micron planning to introduce DIMM-based 3D XPoint product
 - Intel introduced their Optane DIMM products in June 2018
- Emerging NVM market could exceed \$6B by 2028 (Emerging Memories are Poised to Explode, Coughlin Associates and Objective Analysis, <http://www.tomcoughlin.com/techpapers.htm>)



PERSISTENT MEMORY OVER FABRICS (PMoF)

FOR DATA REPLICATION WITH DIRECT LOAD/STORE ACCESS

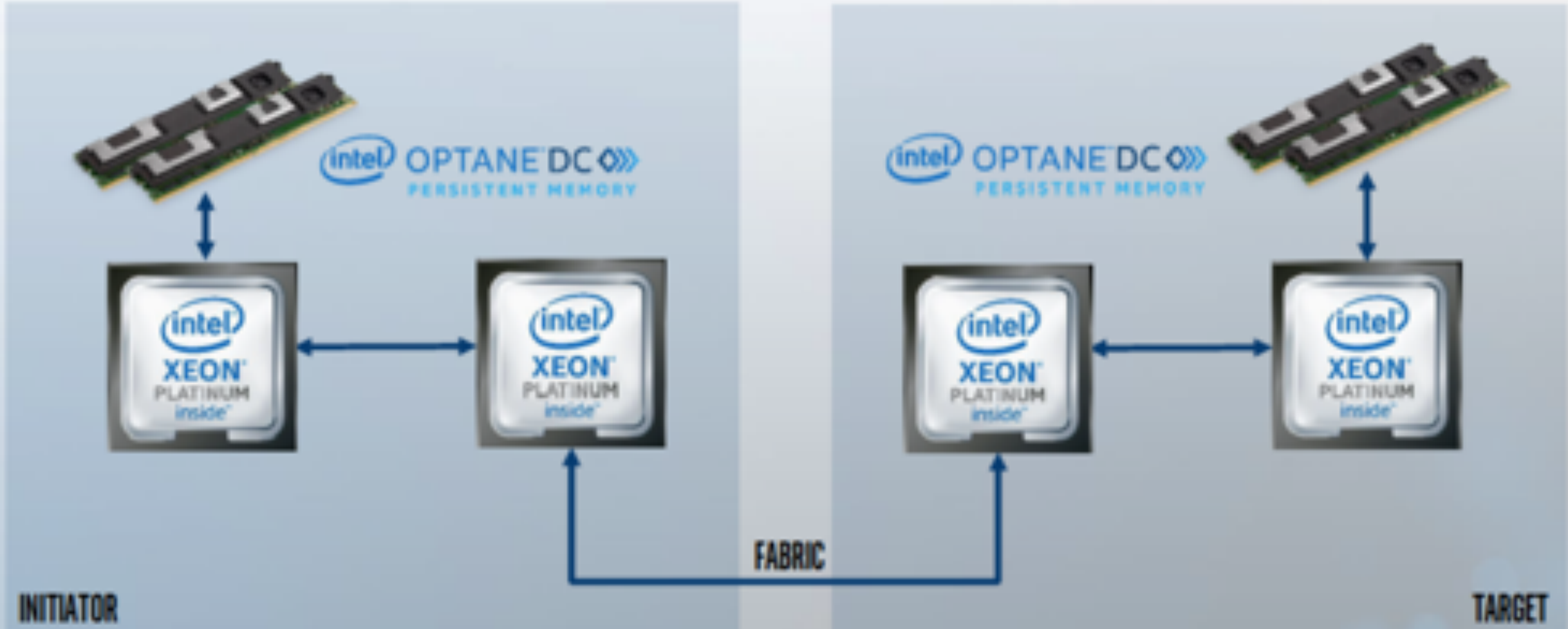

Lightspeeur® 2802M, Production AI Accelerator Chip with MRAM (from 2019 CES)



- ▶ Includes: The GME (Gyr Falcon MRAM Engine)
- ▶ 9.9 TOPS/W in a 22nm ASIC
- ▶ Produced via TSMC Collaboration
- ▶ Industry leading features, like Non-Volatile Memory

~ 40 MB of Memory	Large embedded models	
	Multiple AI models :	
	Image Classification	Facial recognition
	Voice identification	Voice Commands
	Text to speech	And others.....
Power Savings	20-50% when compared to SRAM or “other MRAM”	
Custom Designs	One Time Programmable Memory	
	Up to 10 ns Read Speed (~30 TOPS/W)	
	Non-Power Leakage	

Use of Optane NVMe SSDs

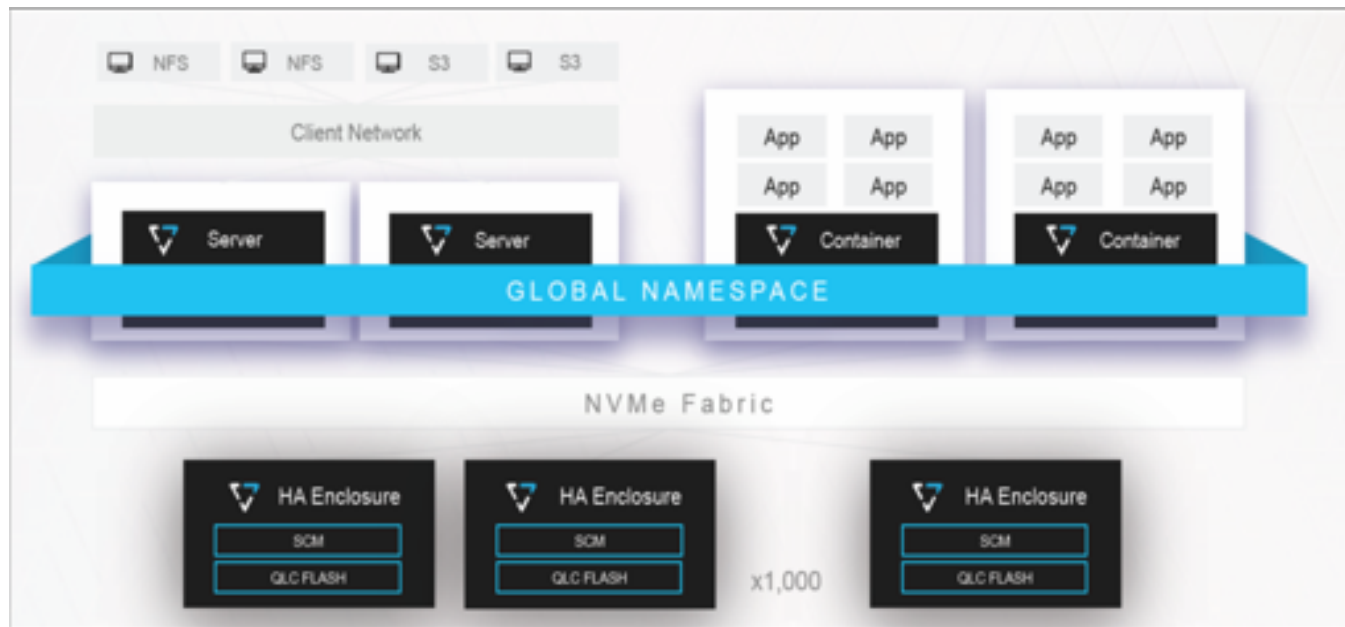

- VAST's Universal Storage uses Intel's Optane (3D X-Point) NVMe SSDs at the front end of their storage, allowing writing at terabytes per second (TB/s) and millions of IOPs and providing a quad-level cell 3D NAND providing exabyte scale file system (NFS) and Object (S3) storage.
- They say that by using NVMe QLC flash and NVMe over Fabric (NVMe-oF) they can bring the costs of their storage system down to be competitive with HDDs, while providing significantly higher performance and long QLC flash life

Timeline for Change

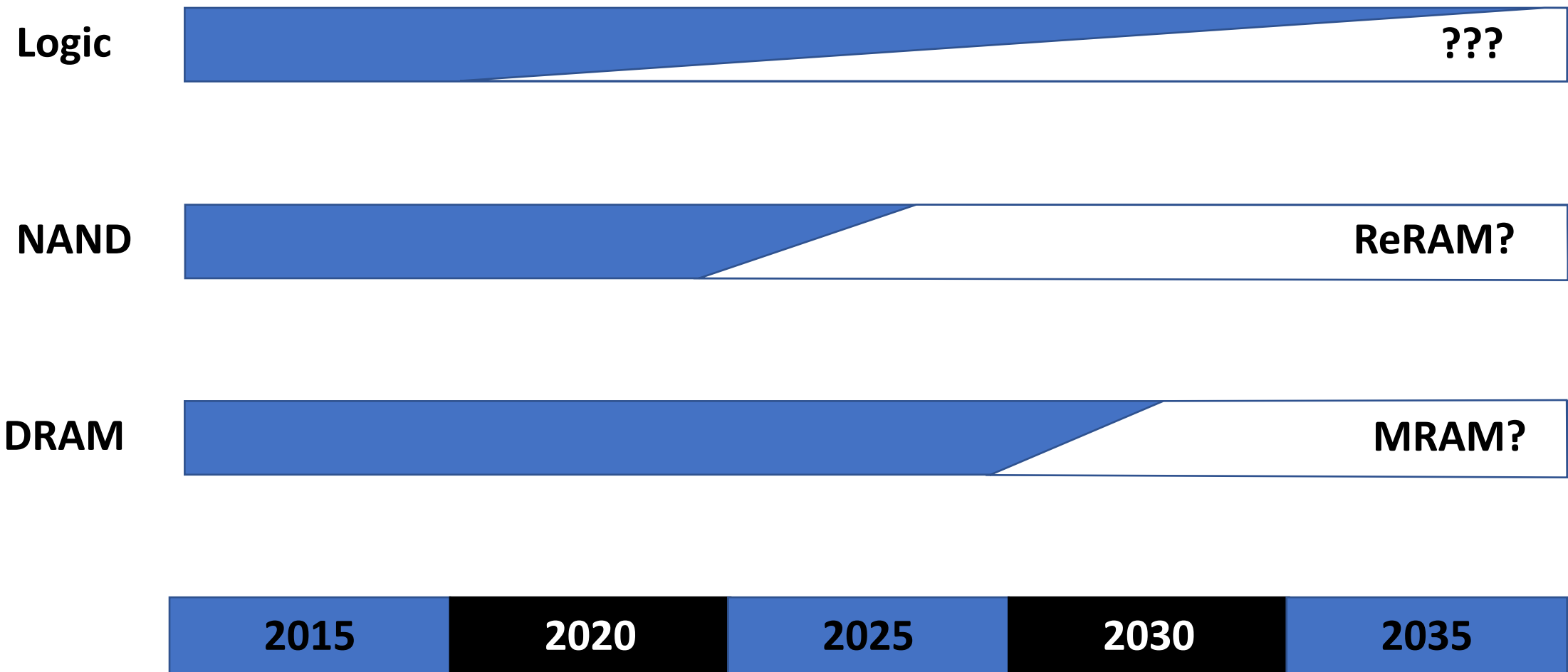

Source: Objective Analysis, 2018

Conclusions

- 5G, IoT and AI will be a factor in the growth of digital content over the next decade and will increase requirements for more digital storage and memory solutions
- The demand for lower latency and power efficiency will drive the use of solid state storage (including emerging memories) as primary storage in data centers and at the network edge
- HDDs and tape will continue to support longer term cold storage
- New storage technologies and architectures as well as traditional storage technologies will provide more efficient memory-centric computing

Report on Emerging Memories

- Flash memory will remain a dominant solid-state memory for several generations with all manufacturers having moved to 3D flash.
- The 3D X-Point technology is poised to impact DRAM production while STT MRAM will impact SRAM, NOR and some DRAM.
- Resistive RAM (ReRAM) appears to be a potential replacement for flash memory sometime in the next decade.
- The memories addressed in this 161-page report, containing 31 tables and 111 figures, include PCM, ReRAM, FeRAM and MRAM Technology as well as a variety of less mainstream technologies.

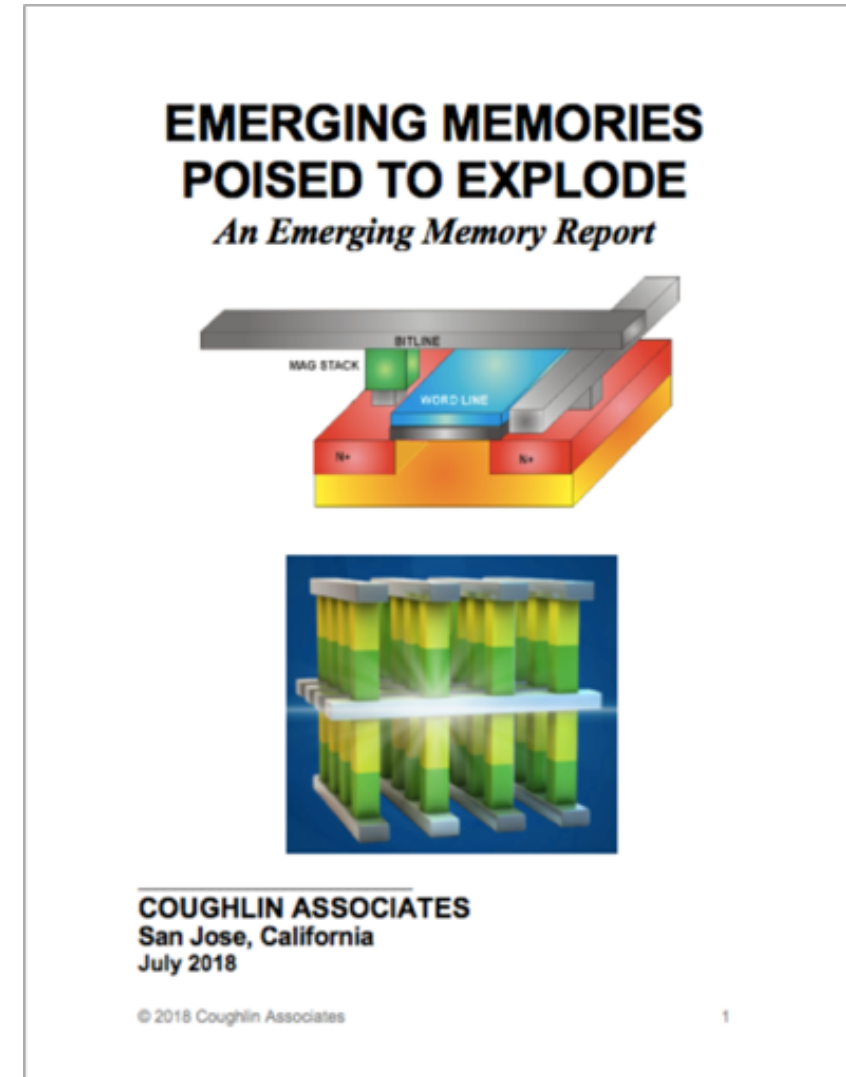

References

- The Memory of Cars, Tom Coughlin, <https://ieeetv.ieee.org/ieee-local-events/the-memory-of-cars-talk-by-tom-coughlin>
- Digital Storage Technology Newsletter, Coughlin Associates, [https://Digital Storage Technology Newsletter, Coughlin Associates,](https://DigitalStorageTechnologyNewsletter.com)
<https://tomcoughlin.com/product/digital-storage-technology-newsletter/>
- 2018 Emerging Memories Poised to Explode: Emerging Memory Report, Coughlin Associates, <https://tomcoughlin.com/product/emerging-non-volatile-and-spin-logic-technology-and-manufacturing-report-2015/>
- 2018 Digital Storage in Media and Entertainment Report, Coughlin Associates, <https://tomcoughlin.com/tech-papers/>

A photograph of a sandy beach with gentle waves in the background. A long, dark shadow of a person is cast across the sand from the left side of the frame. The word "Questions?" is written in large, white, sans-serif font across the middle of the image.

Questions?